



**HINDALCO**  
***EXTRUSIONS***

EXPERTISE IS OUR STRENGTH



**CONSUMER DURABLE  
RENUKOOT**

Printed Jan. 2018



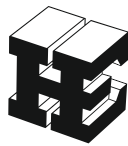

**HINDALCO**  
***EXTRUSIONS***

EXPERTISE IS OUR STRENGTH



## VISION

To be a premium metals major, global in size and reach, excelling in everything we do, and creating value for our stakeholders.

## MISSION

To relentlessly pursue the creation of superior shareholder value, by exceeding customer expectation profitably, unleashing employee potential, while being a responsible corporate citizen adhering to our values.

## VALUES

**Integrity:** Honesty in every action

**Commitment:** Deliver on the promise

**Passion:** Energized action

**Seamlessness:** Boundaryless in letter and spirit

**Speed:** One step ahead always





## Contents

Page No.

### Consumer Durable

1. Ac Filter.....	12
2. Ac Grill.....	12
3. Ac Panels .....	12
4. Ac Parts .....	13
5. Cooker Parts.....	15
6. Cookware Parts.....	16
7. Water Filter.....	17
8. Furnitre .....	17
9. Photo Frames .....	20
10. Moulded Luggage.....	21
11. Fan Parts .....	22
12. Hanger .....	22
13. Letter Plates .....	23
14. Milk Cane .....	24
16. Poultry Channels .....	25
17. Telescopic Tubes.....	27
18. Index .....	28
19. Contacts .....	29

## **HINDALCO - An Overview**

**Hindalco Industries Limited**, a USD 15 billion flagship company of the Aditya Birla Group, is a leading producer of aluminium and copper. Hindalco is present across the value chain of Aluminium & Copper. It has global footprint spanning across 13 countries in 5 continents

### **Aluminium**

- Amongst top 5 aluminium majors worldwide.
- World's largest aluminium rolling company.
- Integrated operations - from mines to alumina to metal to value added products
  - ✦ Ingots & redraw rods (wire rods)
  - ✦ Flat Rolled products
  - ✦ Extrusions
  - ✦ Foils

### **Copper**

- World's largest single-location copper smelting capacity.
- Copper mines in Australia.

Hindalco is a leader in Aluminium Extrusions industry in India with two manufacturing facilities. Both the plants are equipped with state of the art equipment, having well established manufacturing processes and quality systems honed over five decades.

- Manufacturing Facilities
  - ✦ Renukoot, U. P. (North India)
  - ✦ Alupuram, Kerala (South India)
- Capacity 60,000 MT per annum
- Expertise in customised alloys including hard alloys
- Catering to wide range of application segments such as Architectural, Electrical, Industrial, Transport, Defence and Consumer Durable.
- Extrusions manufactured from in-house virgin metal
- Quality Certification
  - ✦ ISO 9001-2008
  - ✦ ISO 14001-2004
  - ✦ OHSAS 18001-2007

This Catalogue covers the Transport sections from the range manufactured in the Renukoot plant of Hindalco



TABLE - 1

**Wrought alloys: Near equivalent designations**

INDIA		U.S.A. (A.A.)	BRITAIN (B.S.)	CANADA	GERMANY (DIN)	RUSSIA	I.S.O.	FRENCH ND
NEW I.S.	OLD I.S.							
19501	1E	1050(E.C)	1E	C 1S	E-Al 99.5	-	-	-
19500	1B	1050	1B	1S	A-99.5	-	Al-99.5	1050A
24345	H15	2014	H15	B26S	AL-CU-SI	AK	-	-
24534	H14	2017	H14	17S/16S	-	D1	Al-Cu-4Mg Si	-
-	-	2024	-	24S	Al-Cu.Mg2	-	Al-Cu-4Mg 1	2024
31000	N3	3003	N3	3S	Al-Mn	A-Mn	Al-Mn 1	3003
52000	N4	5052	N4	M57S	Al-Mg,2	A-Mg	Al-Mg-2.5	5051
53000	N5	5086	N5	54S	-	A-Mg-3	Al-Mg-4	-
54300	N8	5083	N8	D54S	Al-Mg-4.5 Mn	-	Al-Mg-4.5 Mn	5083
65032	H20	6061	H20	65S	Al-Mg-Si Cu	-	Al-Mg-1Si Cu	-
63400	H9	6063	H9	50S	Al-Mg-Si 0.5	-	Al-Mg Si	-
64430	H30	6351	H30	B51S	Al-Mg-Si 1	AV	Al-Si-1 Mg	6081
64423	H11	6066	H11	C62S	-	-	-	-
62400	-	6005	-	C51S	-	-	-	-
63401	91E	6101	91E	D50S	E,Al,Mg,Si 0.5	-	-	-
64401	-	6201	-	-	-	-	-	-
74530	-	7039	-	D74S	Al-Zn-Mg,1	-	-	3004
-	-	7075	DTD 5124	75S	Al-Zn-Mg Cu 1.5	-	Al-Zn 6 Mg Cu	7075



TABLE - 2

**Wrought alloys: Guide to selection**

Alloy	Temper	Resistance to Corrosion	Workability (Cold)	Machinability	Brazeability	Weldability	Commonly available forms	Indications of use
EC/1050, 1060 (1B) (19501) (19500) (19600)	F, O	A	A	D	A	A	Flats, Rods, Tubes & other section	Electrical conductors, cable sheathing, impact-extruded products, pressing utilities of anodizing quality, pen caps, piping etc.
1100 (1C) (19000)	F, O	A	A	D	A	A	Flats, Rods, Tubes & other section	Packaging lightly stresses and decorative assemblies in architecture and transport, equipment for chemical, food and brewing industries.
2014 (H 15) (24345)	T4 T6	C C	C D	B B	D D	C C	Rods & Bars Rods & Bars	Highly stressed component of all types in aircraft, ordnance and general engineering.
2017 (H 14) (24534)	T4	C	C	B	D	C	Rods & Bars	Highly stressed parts in aircraft and other structures, screw machine products.
2024	T4	C	C	B	D	C	Rods & Bars	Load Cell, Highly stressed component of all types in aircraft, ordnance and general engineering.
4043 (N 21) (43000)	F, O	A	A	D	A	A	Rods & other sections	Welding wire, architectural applications
5005 (52000A)	O, F	A	A	D	B	A	Flats, Rods, other sections	Structures exposed to marine attractive anodized finish, architectural, electrical conductors etc.
5052 (N 4)	O, F	A	A	D	C	A	Flats, Rods, Tubes & other sections	Structures exposed to marine atmosphere, aircraft parts, wire rope ferrules, rivet stock.
5086 (N 5) (53000)	O, F	A	A	D	D	A	Flats, Rods & other sections	Ship building and other marine applications, rivets, coinage etc.
5056 (N 6) (55000)	O, F	A	A	D	D	A	Rods	Zips, Welding Rods and Rivets.
6061 (H 20) (65032)	O, F T4 T6	A A A	A C D	D C C	A A A	A A A	Rods, Flats, Tubes & other sections	Heavy duty structures, building hardware, sections for bus body, truck and rail coach, furniture, rivets etc.
6063 (H9)	O, F T4 T6 T5	A A A A	A B C C	D C C C	A A A A	A A A A	Rods, Flats, Tubes & other sections	Building hardware, architectural section with good surface finish, medium strength furniture and anodized sections.





TABLE - 2

**Wrought alloys: Guide to selection**

Alloy	Temper	Resistance to Corrosion	Workability (Cold)	Machinability	Brazeability	Weldability	Commonly available forms	Indications of use
6066 (22450)	O, F T4 T6	B B B	B C C	D B B	A A A	A A A	Rods and other solid sections	For welded structures, textile parts, heavy duty machine parts.
6101 (91 E) (63401)	T4 T6	A A	B B	C C	A A	A A	Rods, Flats, Tubes & other sections	High strength electrical busbar sections.
6201 (64401)	T4	A	A	C	A	A	Redraw Rod	Overhead conductors, ACAR and AAAC
6351 (H 30) (6430)	O, F T4 T6	A A A	A C D	D C C	A A A	A A A	Rods, Flats, Tubes & other sections	Structural and general engineering items such as rail & road transport vehicles, bridges, cranes, roof trusses, rivets etc.
7039 (D74S) (74530)	O, F T4 T6	A A A	A C D	D C C	A A A	A A A	Flats, Tubes, Rods & other sections	Defence structures like mobile bridges etc. Tread and chequered plates, Excellent welding property with no loss of strength in welded zone.
7075 (DTD5124)	O, F T4 T6	A A A	A A D	A A A	A A A	A A A	Rods	Highly stressed structural applications

**Notes:**

1. Relative ratings for corrosion, workability and machinability in decreasing order of merit A, B, C and D.
2. Weldability & brazeability ratings A, B, C and D are relative ratings defined as follows:
  - A. Generally weldable by the commercial procedure & methods.
  - B. Weldable with special technique.
  - C. Limited weldability due to crack sensitivity or loss in corrosion resistance and mechanical properties.
  - D. Generally not weldable.
3. Availability of other forms subject to special enquiries and methods.



TABLE - 3

**Wrought alloys: Chemical composition limits (per cent)**

Alloy (ISS) Old	New	Equivalent alloy (AA) U.S.A.	Copper		Magnesium		Silicon		Iron Max.	Manganese		*Others (Total) Max.	Remarks
			Min.	Max.	Min.	Max.	Min.	Max.		Min.	Max.		
1C	19000	1100	-	0.10	-	-	-	0.5	0.6	-	0.1	0.1	Aluminium 99.0% Min
1 B	19500	1050	-	0.05	-	-	-	0.25	0.4	-	0.05	0.1	Aluminium 99.5% Min
1 E	19501	-	-	0.04	-	-	-	0.15	0.35	-	0.03	0.1	Aluminium 99.5% Min
-	19600	1060	-	0.05	-	-	-	0.25	0.35	-	0.03	0.1	Aluminium 99.6% Min
H 15	24345	2014	3.8	5.0	0.2	0.8	0.5	1.2	0.7	0.3	1.2	0.5	-
H 14	24534	2017	3.5	4.7	0.4	1.2	0.2	0.7	0.7	0.4	1.2	0.5	-
		2024	3.8	4.9	1.2	1.8	-	0.5	0.5	0.3	0.9	0.15	Zn 0.25
N 3	91000	3003	-	0.1	-	0.1	-	0.6	0.7	1.0	1.5	0.4	-
		4032	0.8	1.3	0.8	1.3	-	13.5	0.6	-	0.2	0.15	Ni 0.8 - 1.3
N 4	52000	5052	-	0.1	1.7	2.6	-	0.6	0.5	-	0.5	0.4	Cr + Mn = 0.5
M 5	53000	5086	-	0.1	2.8	4.0	-	0.6	0.5	-	0.5	0.4	Cr + Mn = 0.5
N 8	54300	5083	-	0.1	4.0	4.9	-	0.4	0.7	0.5	1.0	0.4	Chromium up to 0.25
H 20	65032	-	0.15	0.4	0.7	1.2	0.4	0.8	0.7	0.2	0.8	0.4	**Cr = 0.15 - 0.35
-	-	6061	0.15	0.4	0.8	1.2	0.4	0.8	0.7	-	0.15	0.4	Chromium 0.04 to 0.35
H 9	63400	6063	-	0.1	0.4	0.9	0.3	0.7	0.6	-	0.3	0.4	-
-	-	6066	0.7	1.2	0.8	1.4	0.9	1.8	0.7	0.6	1.1	0.4	-
-	64423	-	0.5	1.0	0.5	1.3	0.7	1.3	0.8	-	1.0	-	-
9 1E	63401	6101	-	0.05	0.4	0.9	0.3	0.7	0.5	-	0.03	0.1	-
H 30	64430	6351	-	0.1	0.4	1.2	0.6	1.3	0.6	0.4	1.0	0.3	-
		6082	-	0.1	0.6	1.2	0.7	1.3	0.5	0.4	1.0	0.3	Chromium up to 0.25
-	74530	7039	-	0.2	1.0	1.5	-	0.4	0.7	0.2	0.7	0.4	Zinc 4.0 - 5.0 %
-	-	7075	1.2	2.0	2.1	2.9	-	0.5	0.5	-	0.3	0.2	Zinc (5.1 - 6.1) % & Chromium(0.18-0.28) %

\* Titanium and/or other grain refining elements

\*\* Either Mn or Cr shall be present



TABLE - 4

## Wrought alloys: Mechanical properties

Heat Treatable Alloys					
Alloy A A Old (ISS) New (ISS)	Temper	Ultimate Tensile Strength Kg/mm <sup>2</sup>		0.2% Proof Stress Kg/mm <sup>2</sup>	Elongation On 50mm GL
		Min.	Max.		
2014 [H15] [24345]	T4[W]	39	-	24.0	10
	T6 [WP]	49	-	43.0	6
2017 [H14] [24534]	T4[W]	39	-	24.0	10
2024 [H9]	T4	40.5	-	26.5	12
6063 [H9] [63400]	T4[W]	14	-	8.0	14
	T6 [WP]	19	-	15.5	7
6061 [H20] 65032]	M	11.2	-	5.1	12
	T4[W]	19	-	11.5	14
	T6 [WP]	28.5	-	24.0	7
6351[H30] [64430]	M	11.2	-	8.2	12
	T4[W]	19	-	12.0	14
	T6 [WP]	31.5	-	27.5	7
6066	M	11.0	-	-	12
	T4[W]	28	-	17.5	14
	T6 [WP]	35	-	31.5	7
6101[91E] [63401]	T4[W]	14	-	8.0	12
	T6 [WP]	20.5	-	17.0	10
6201 [64401]	T4[W]	16	-	7.0	14
	T8 [WDP]	32	-	-	3
7039 [74530]	T4[W]	28	-	23.5	9
	T6 [WP]	31.5	-	26.5	7
7075	T6 [WP]	54	-	46.5	6

Properties indicated herein are typical properties and are given for information only. However properties of all the profiles in specific alloy shall be as per I. S. Specification.



A.C. Filter

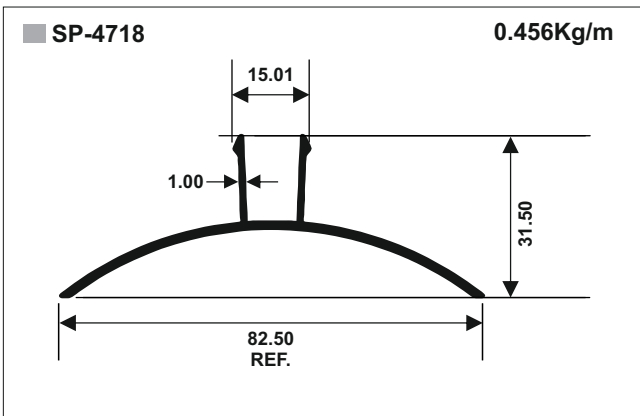
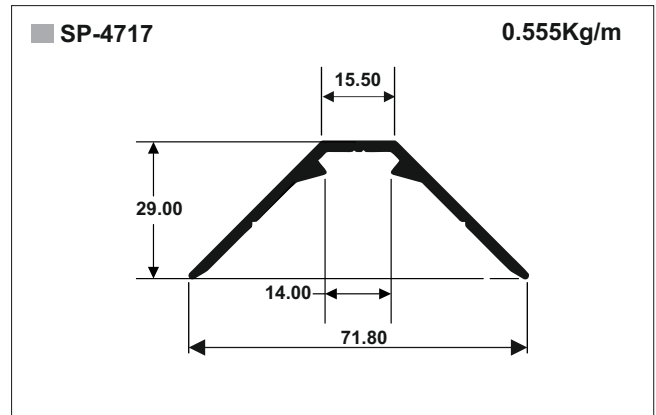
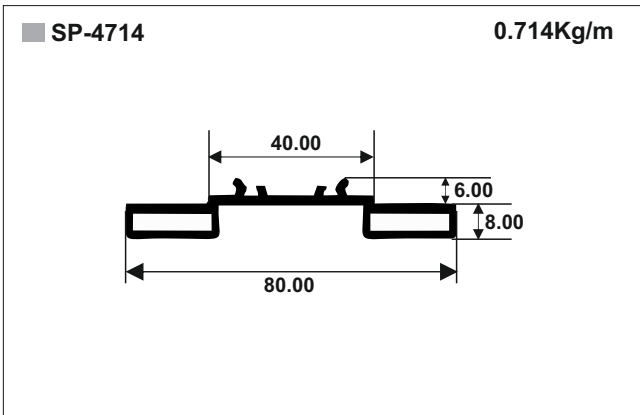

A.C. Grills

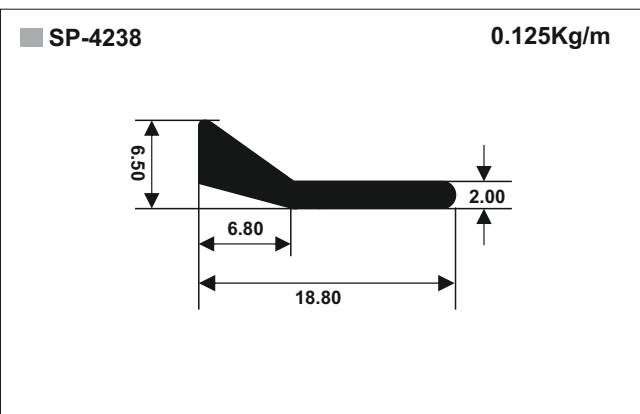
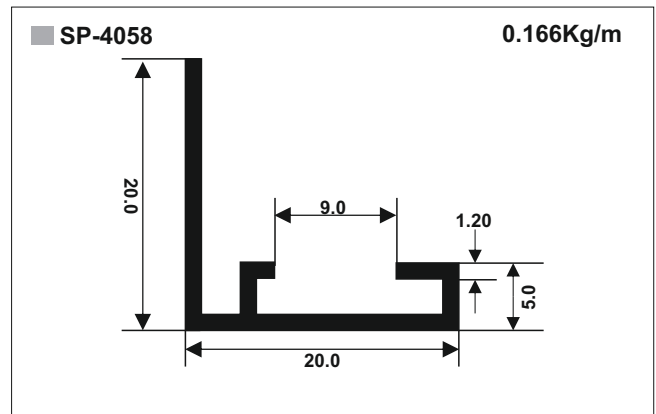
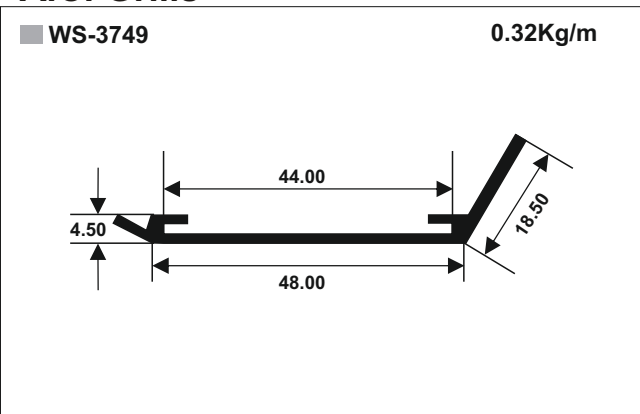



A.C. Part

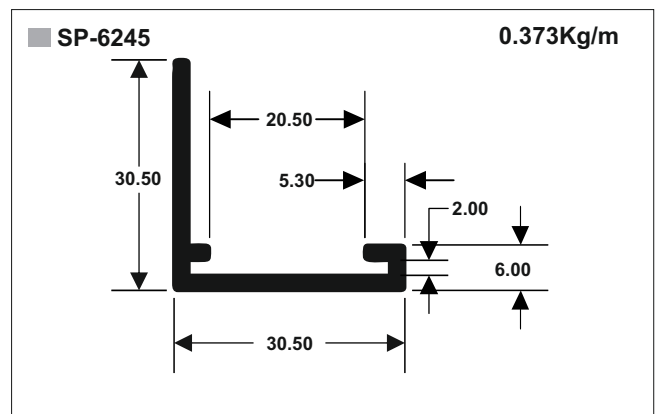
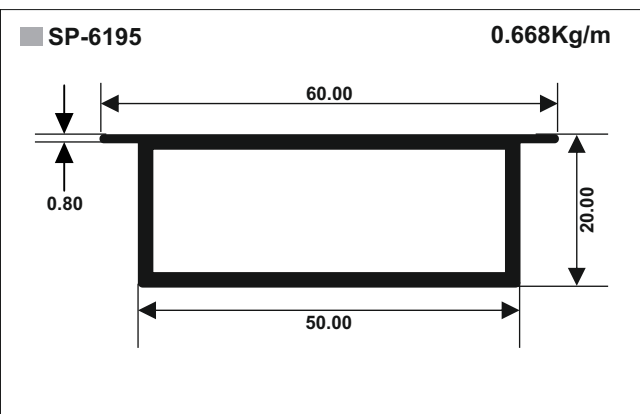
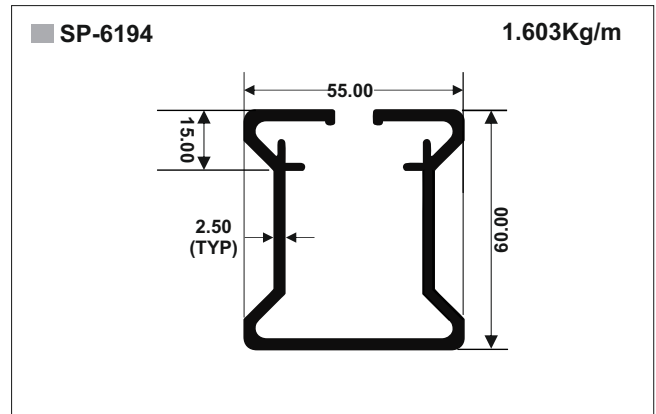
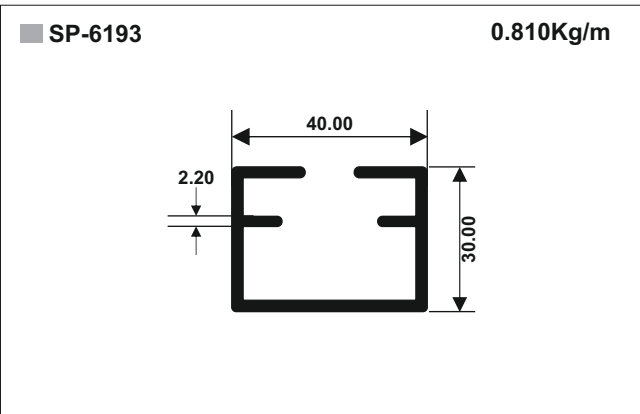
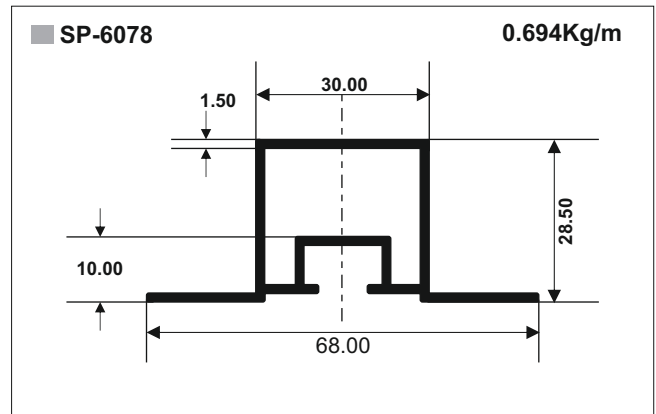
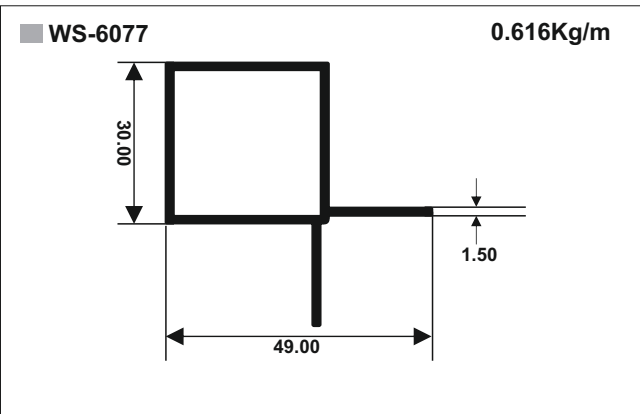
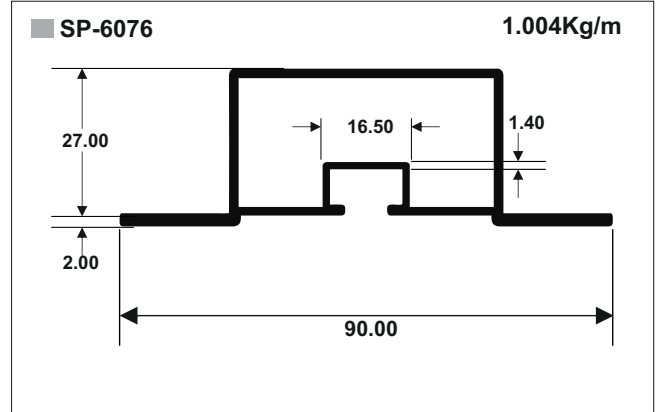
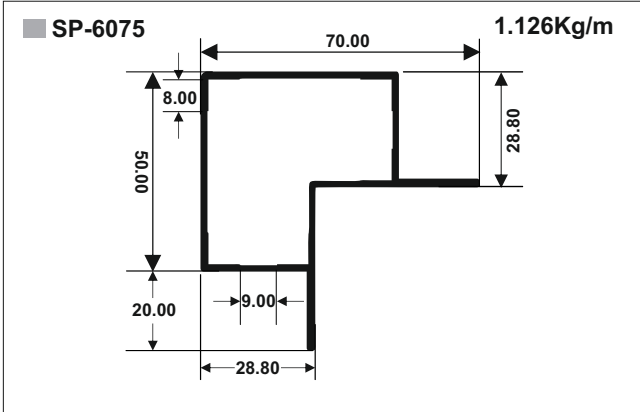



A.C. Part

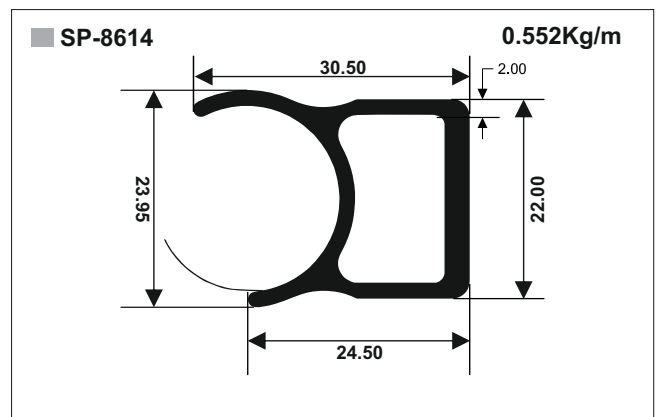
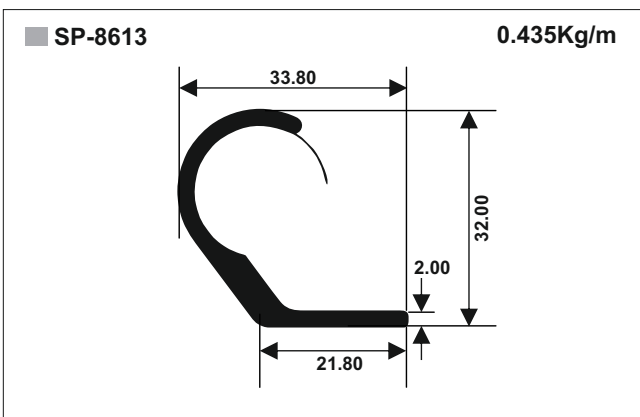
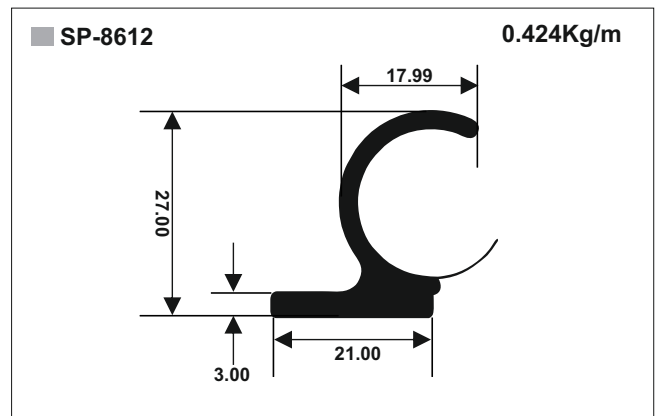
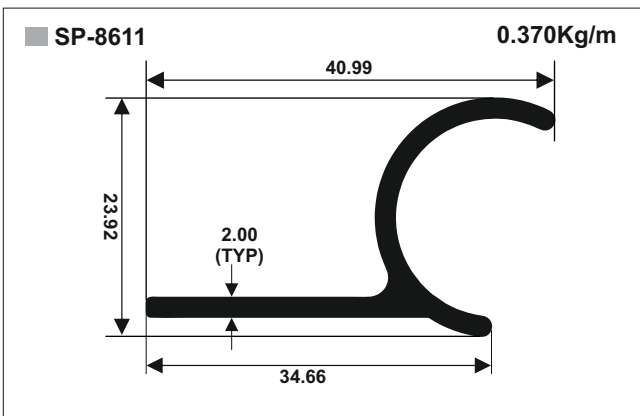
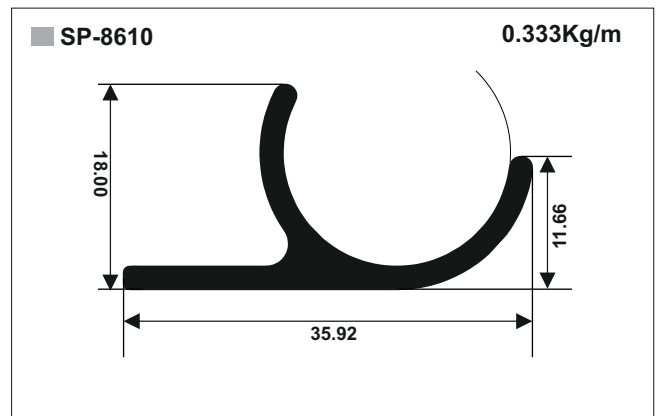
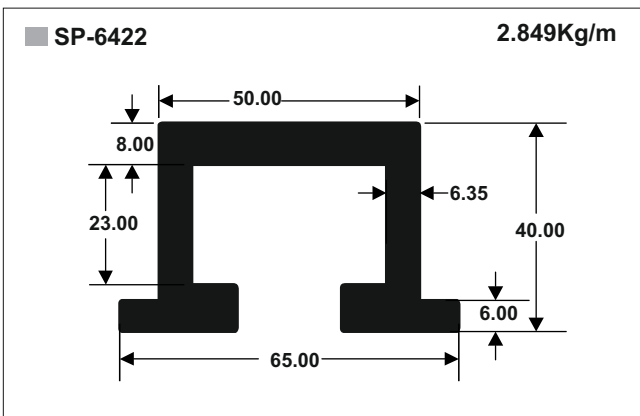
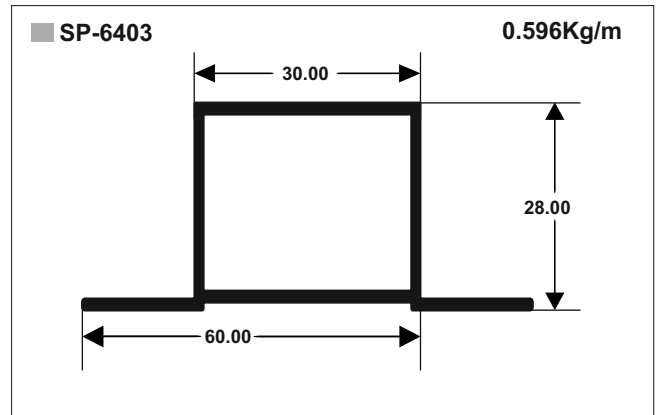
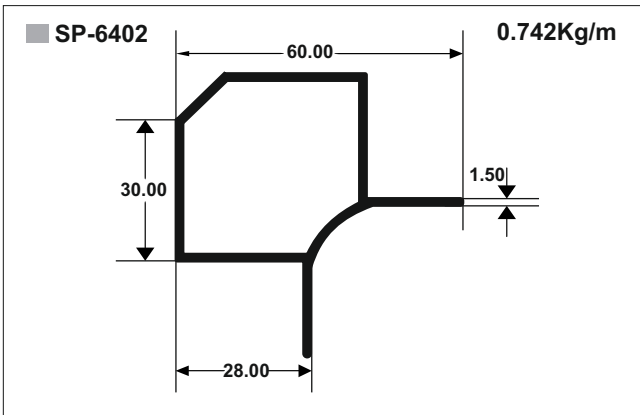



Anodised Article

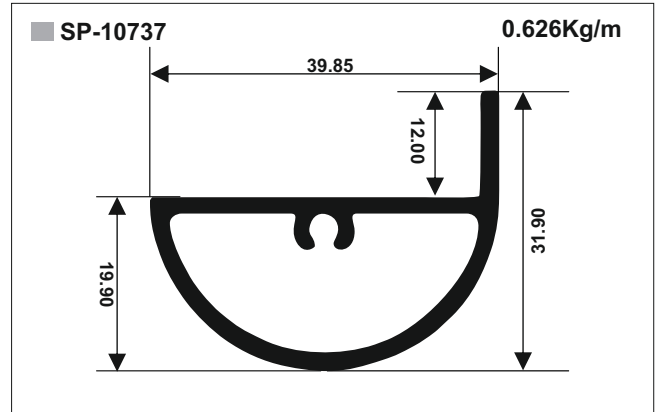
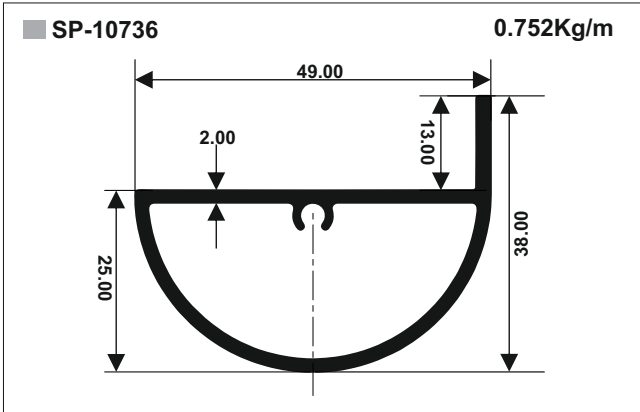

Cooker Parts

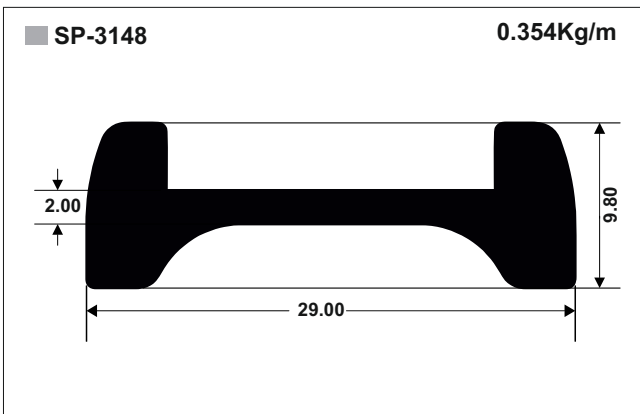
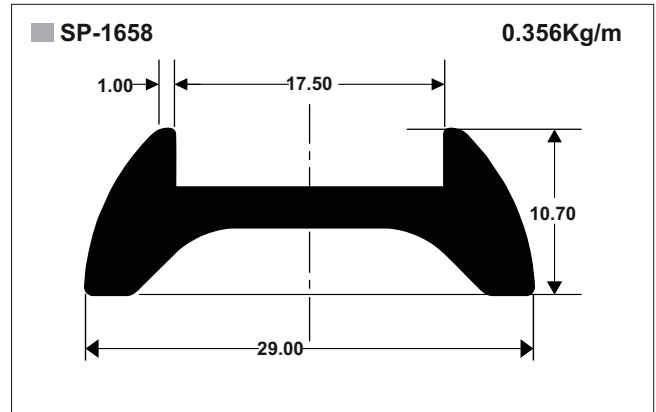
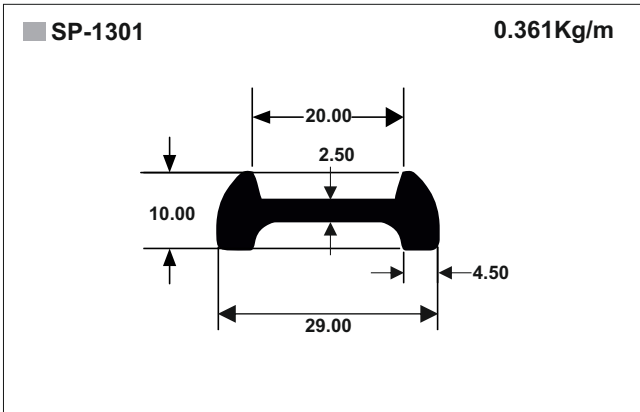

Cooker Handles

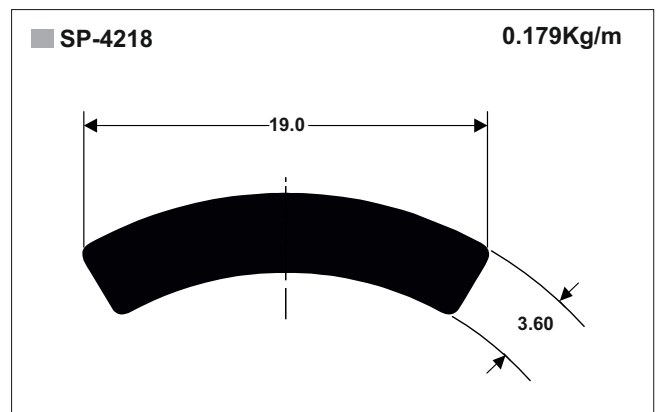
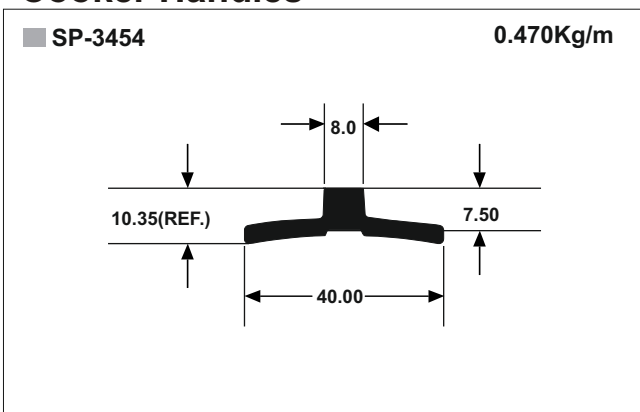



Cookware Parts

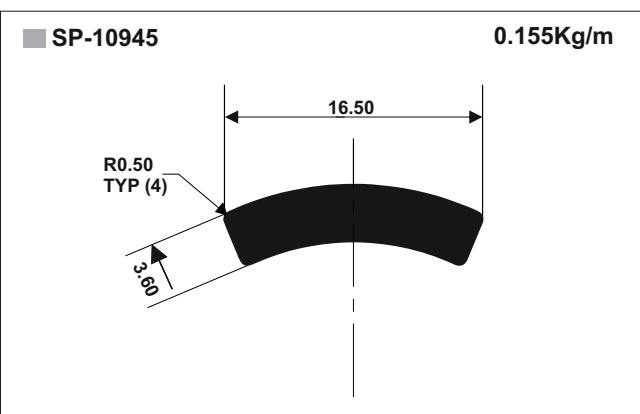
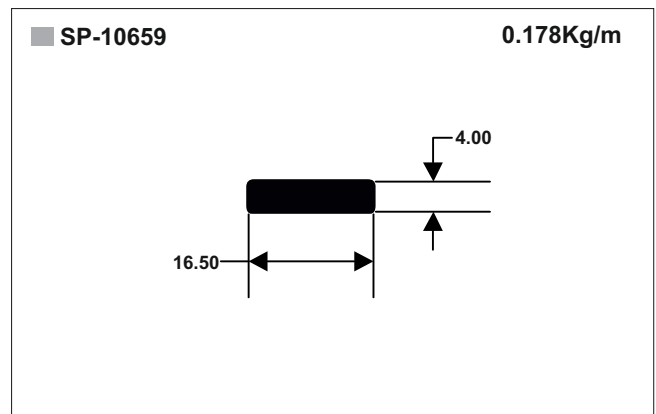
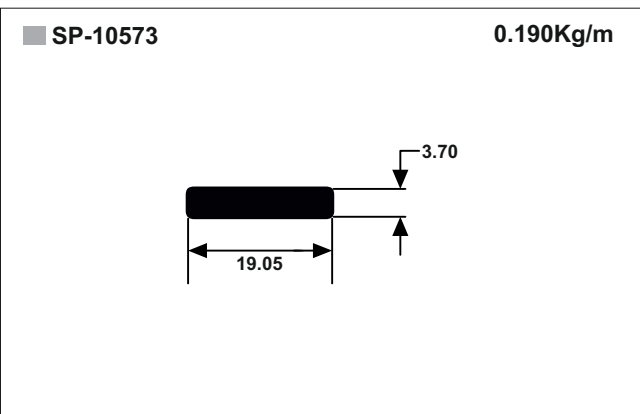
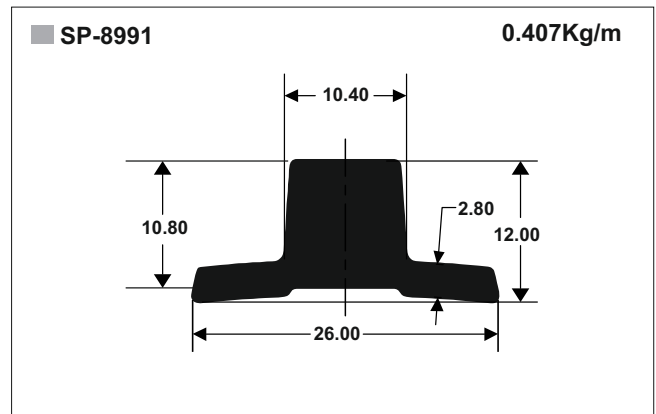
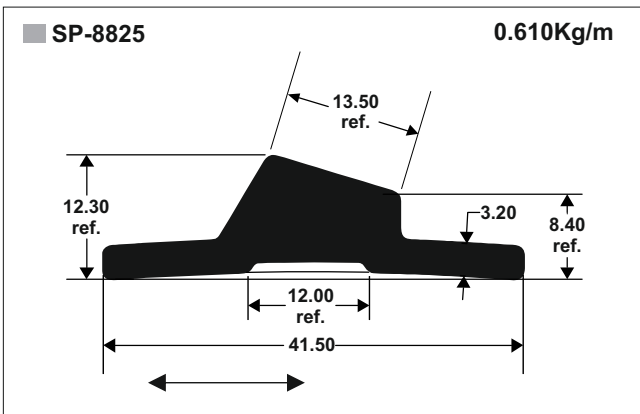
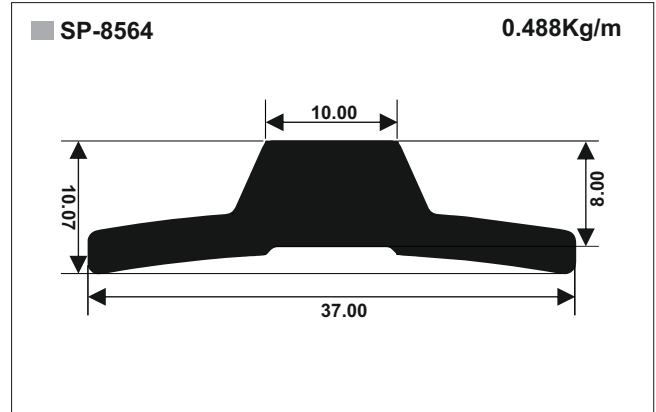
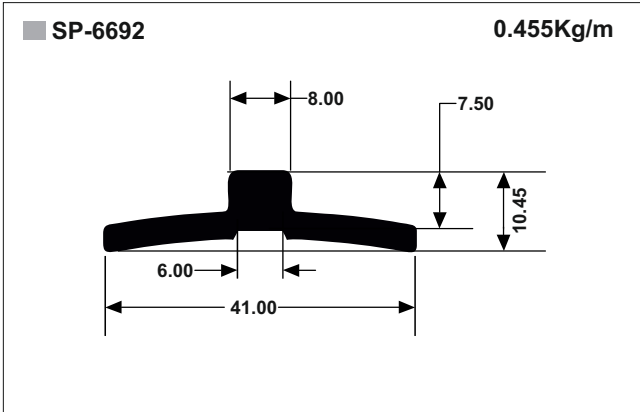





Water Filter

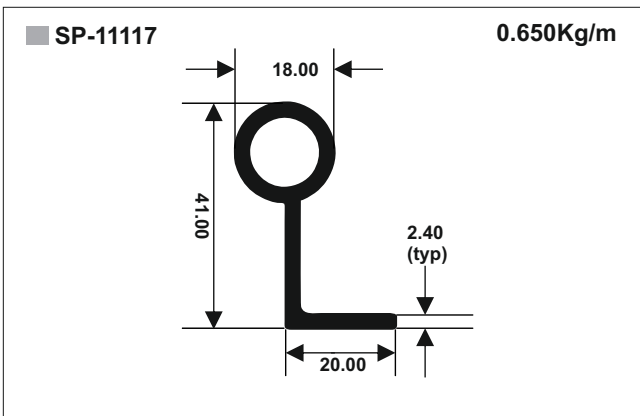
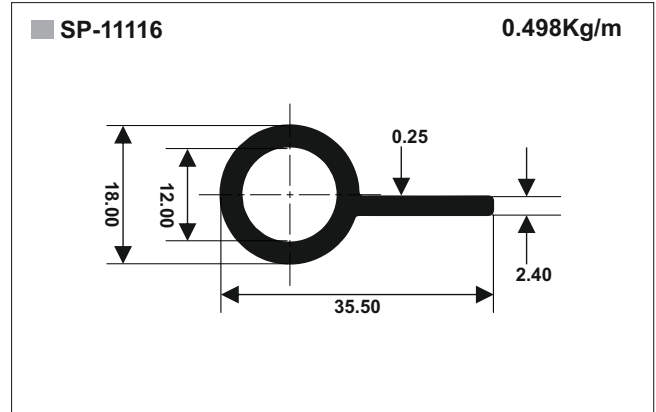
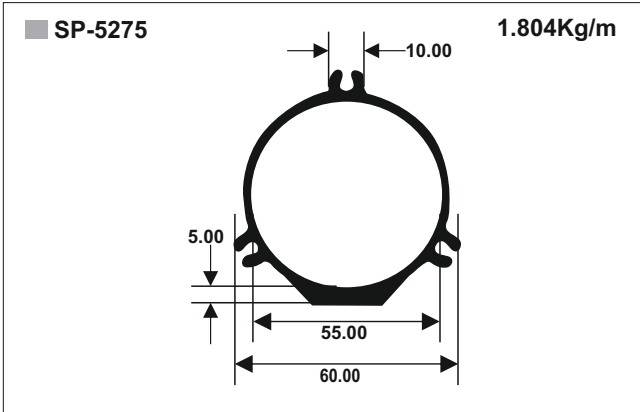

Furniture

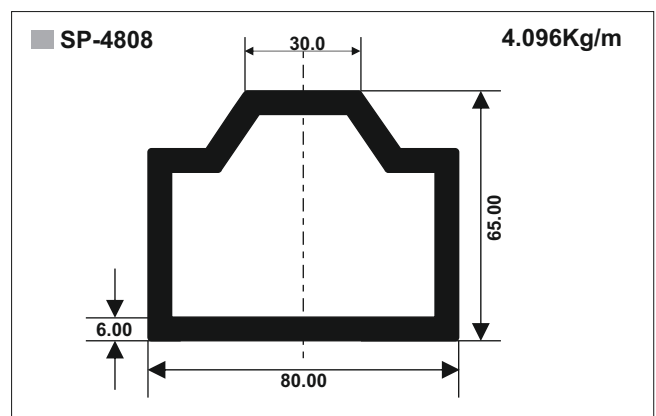
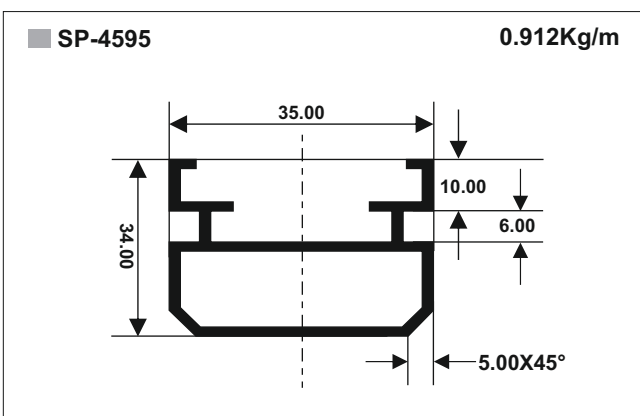
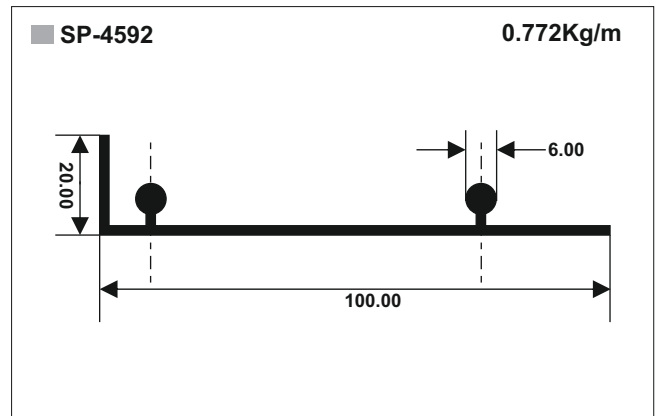
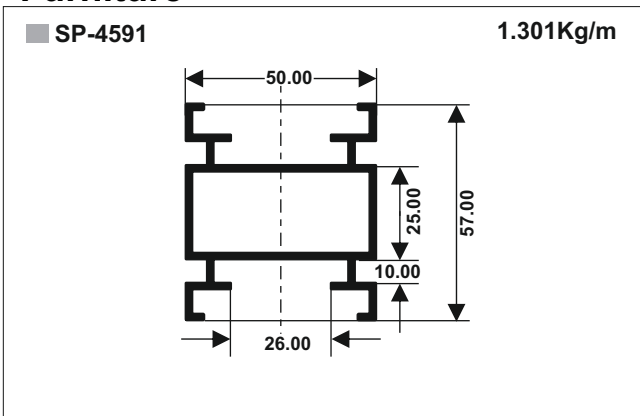



Furniture

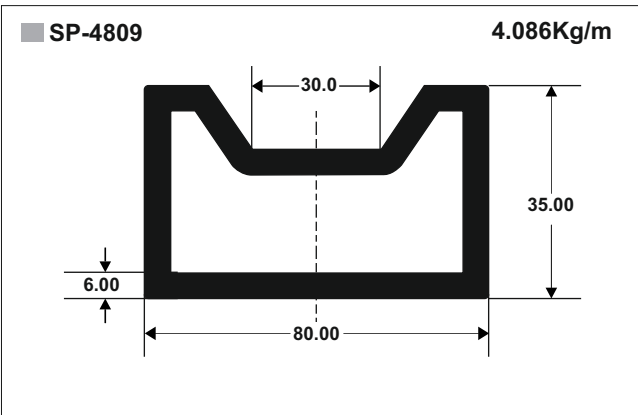

Furniture Drawer Nob

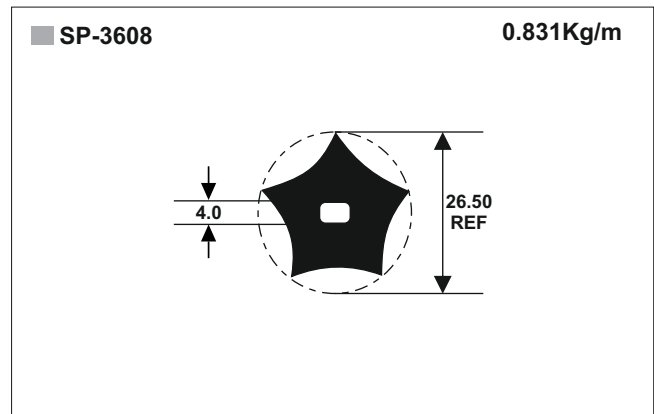
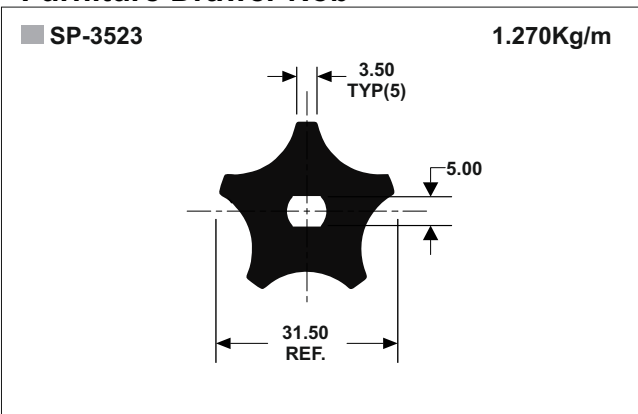

Furniture - Kitchen Shelf

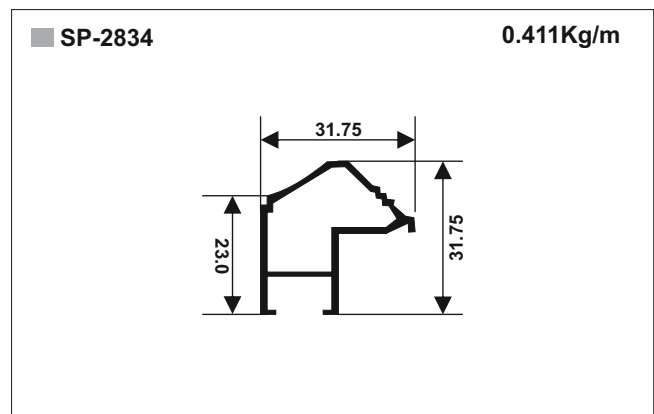
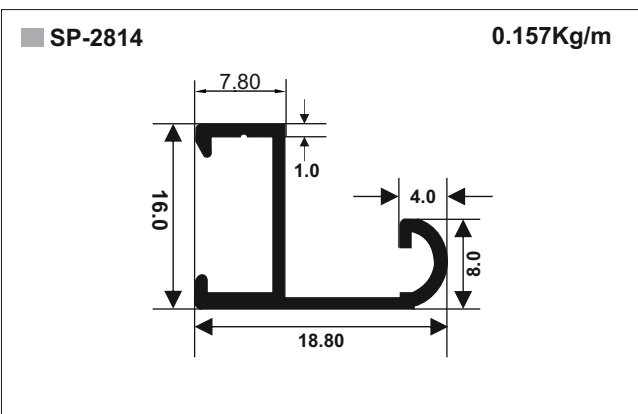
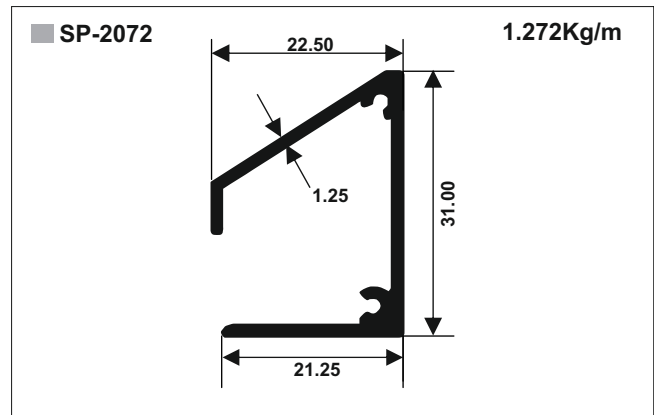
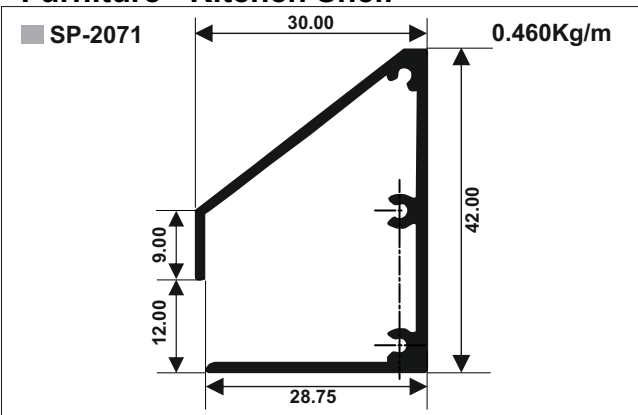



Furniture - Kitchen Shelf

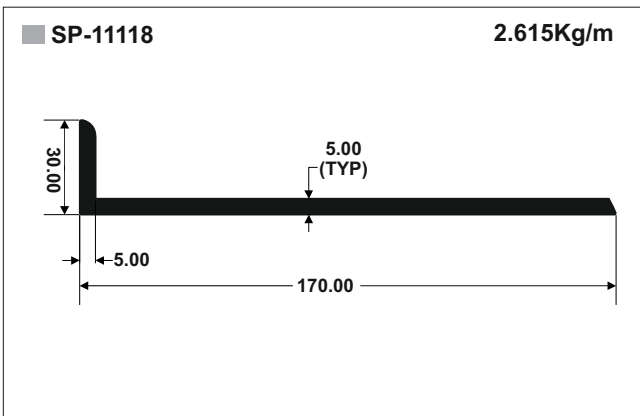
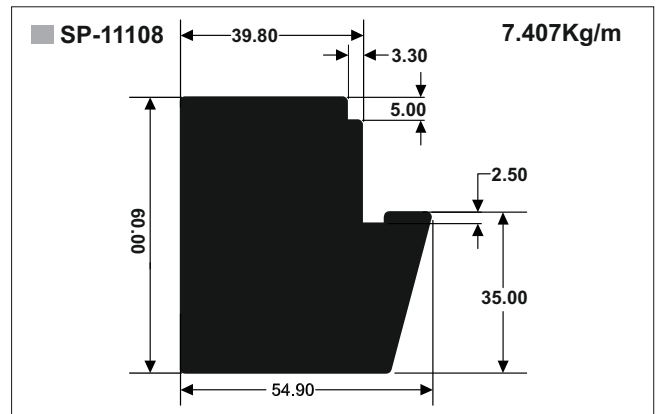
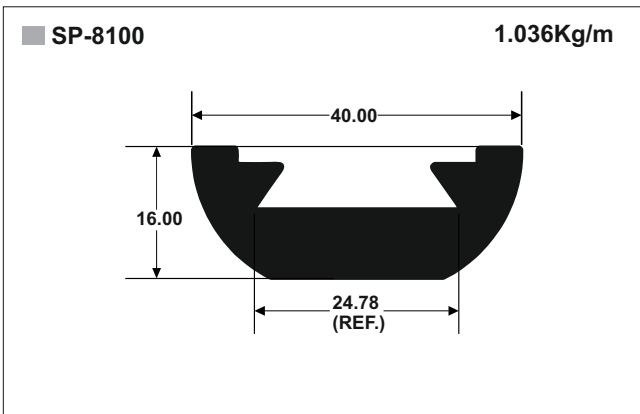
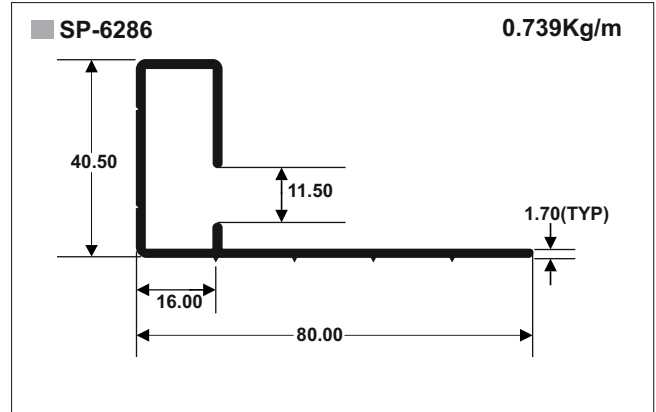
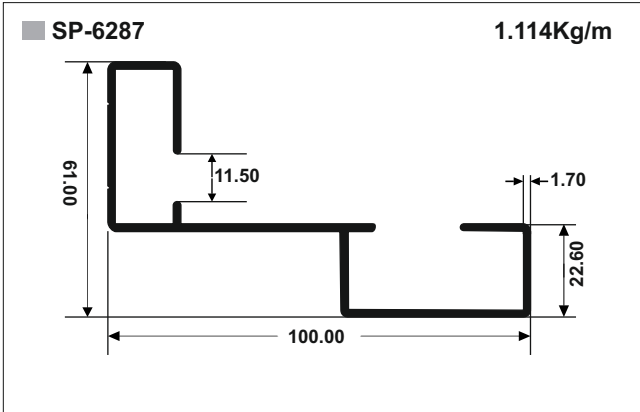

Utensils

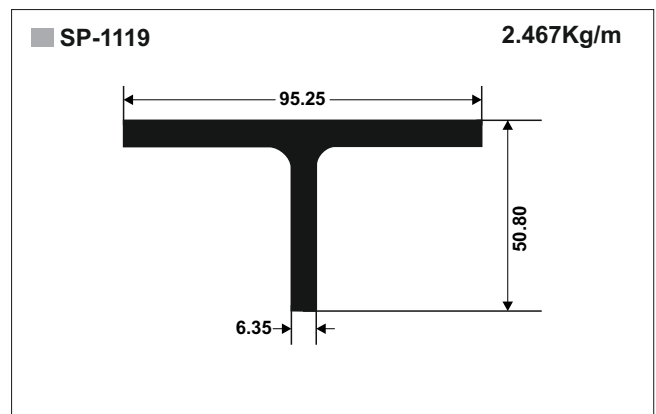
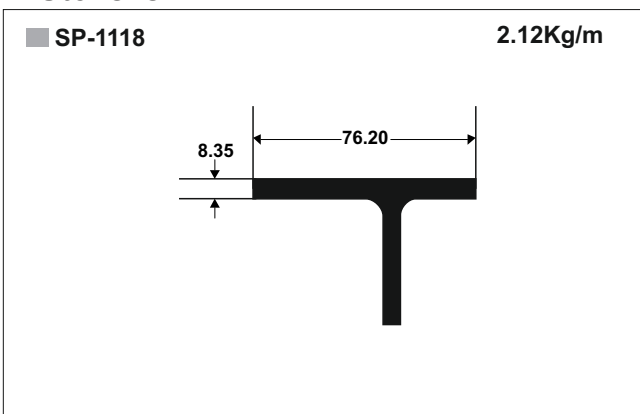



Photoframe

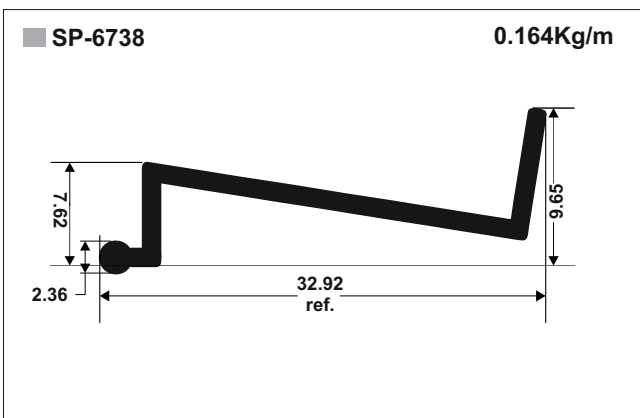
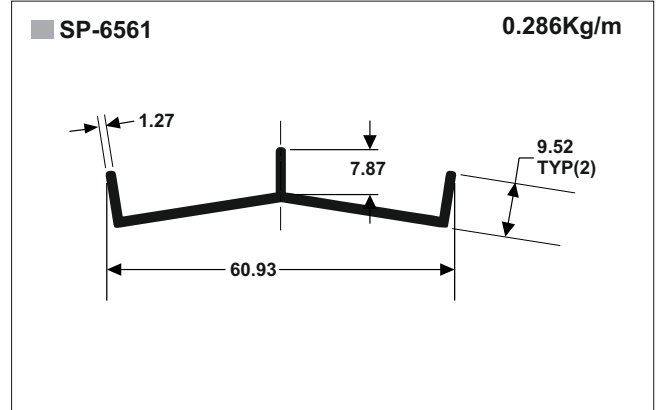
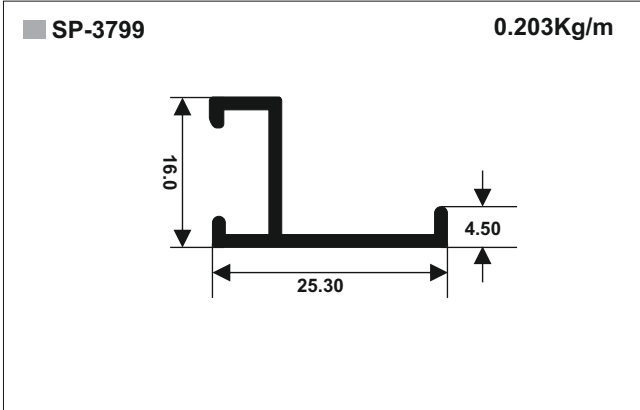

File Cover Clip

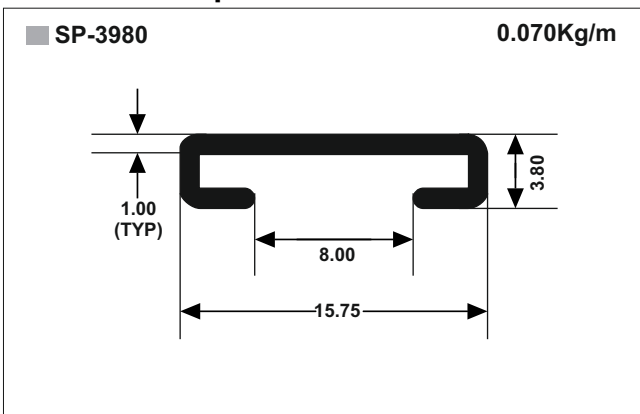



Moulded Luggage

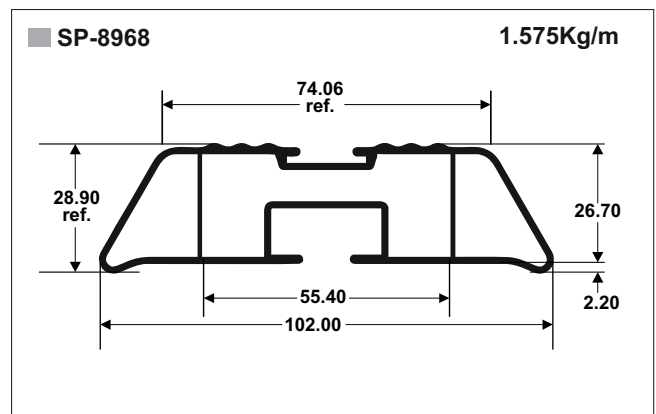
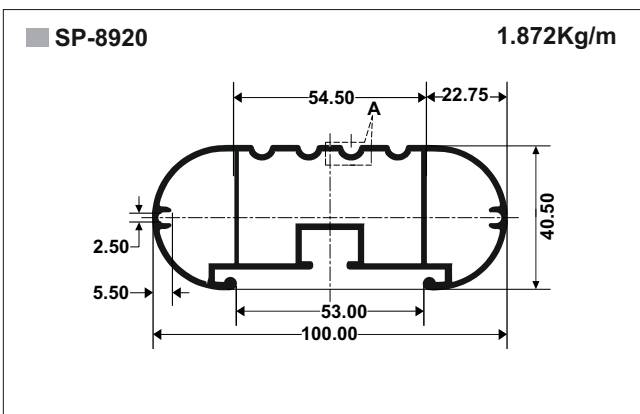
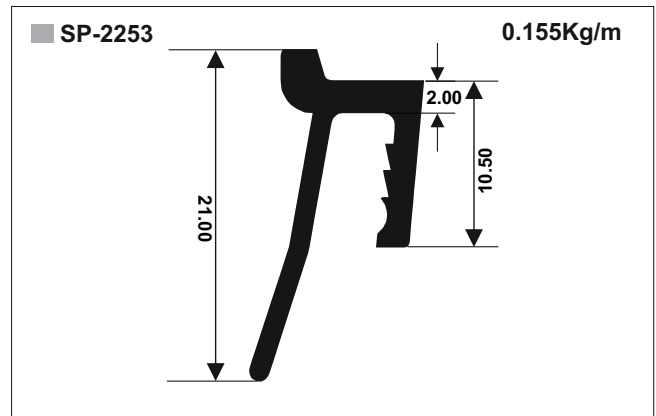
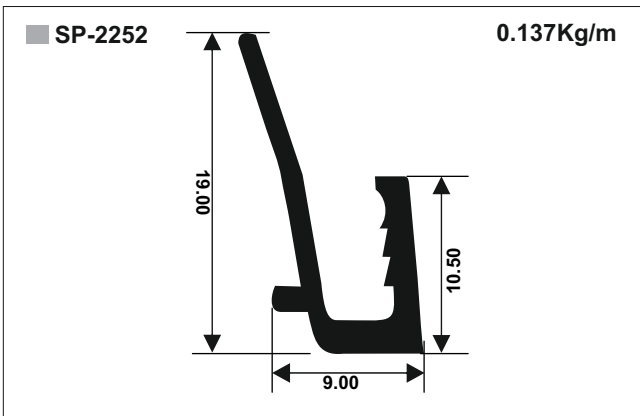
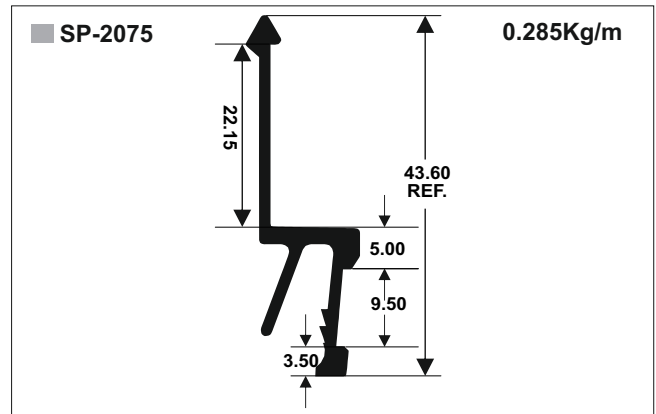
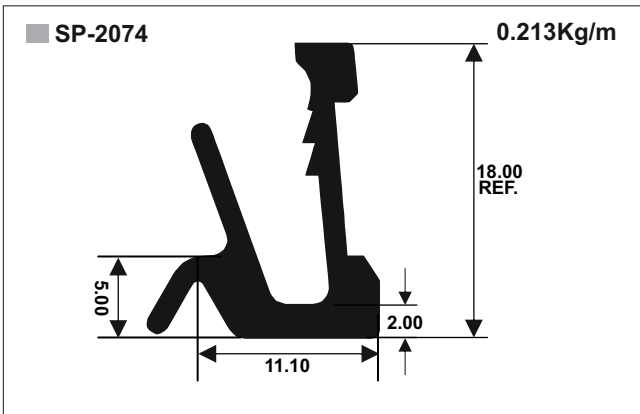
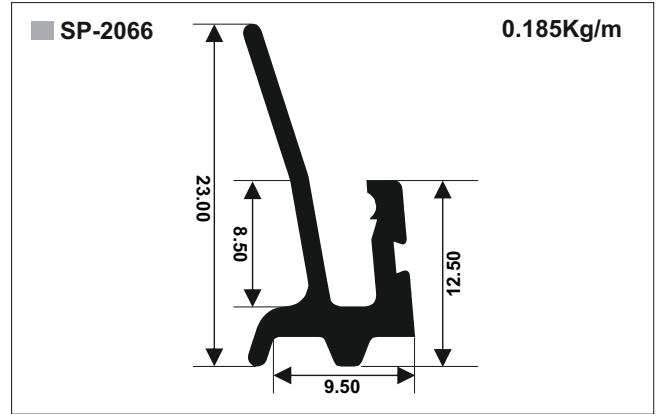
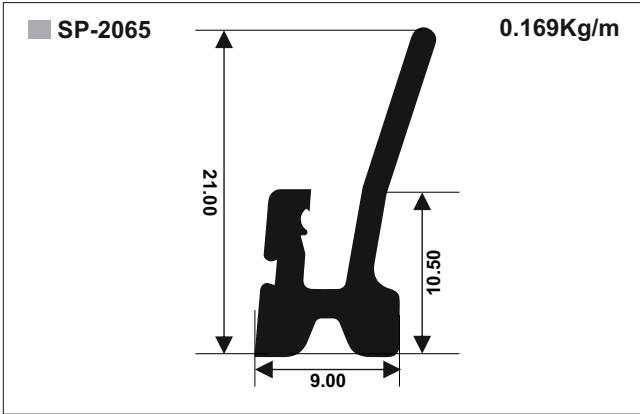



Fan Parts

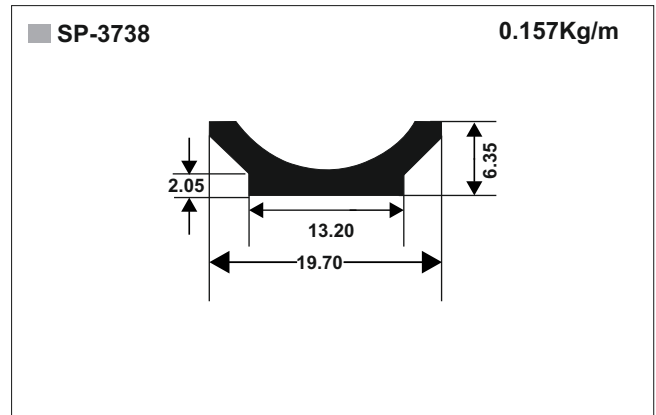
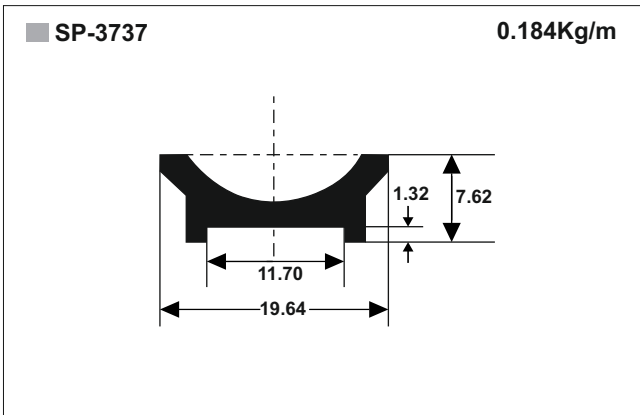

Hanger

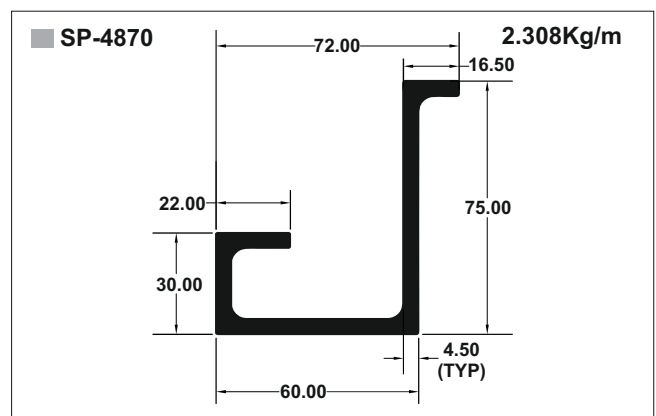
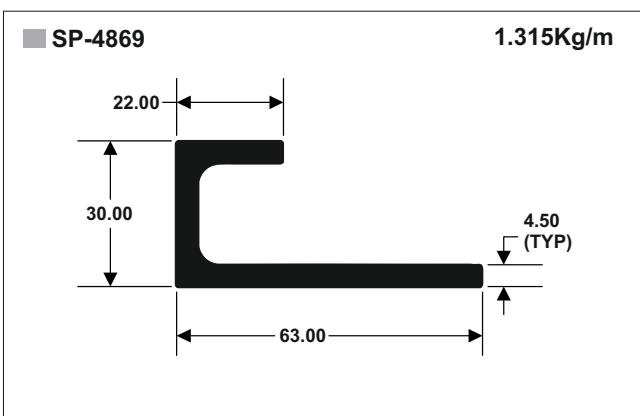
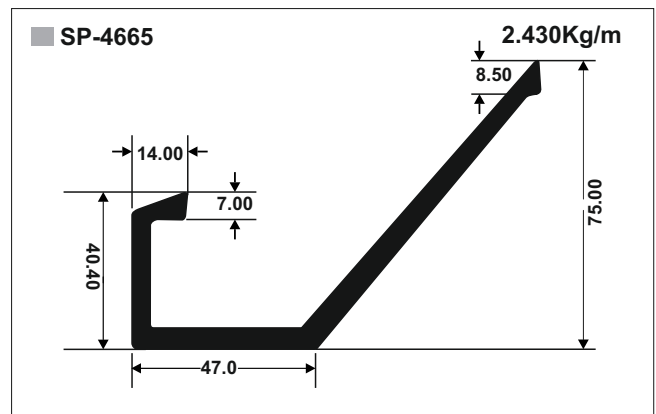
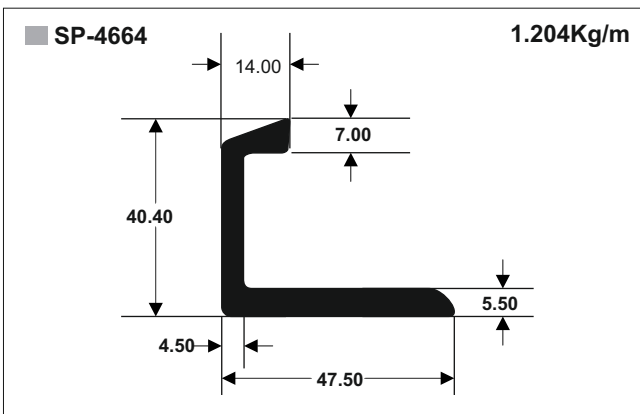
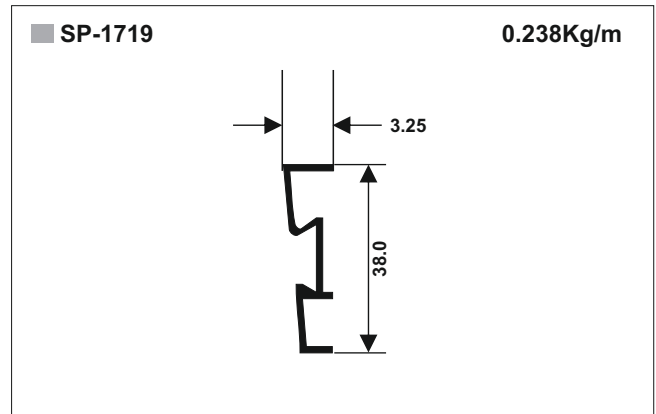
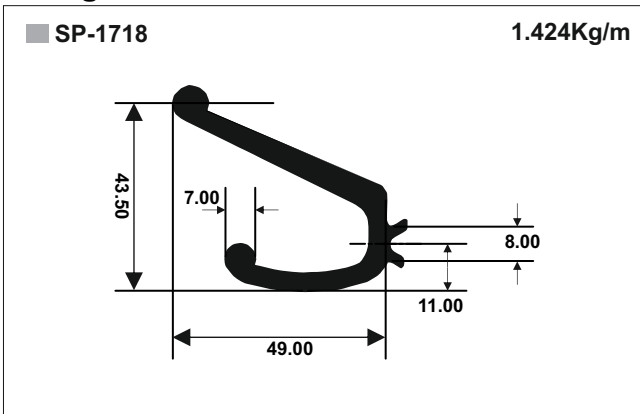



Letter Plate

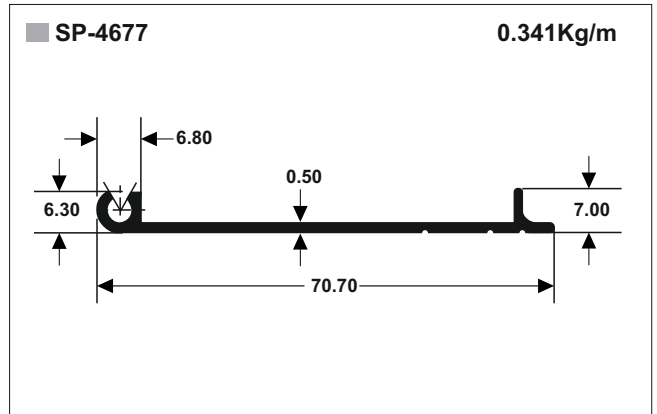
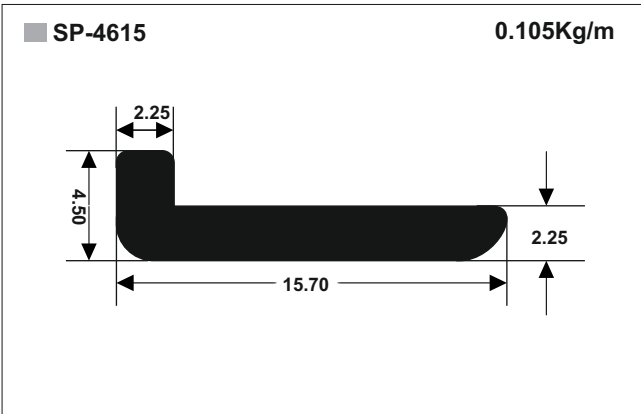
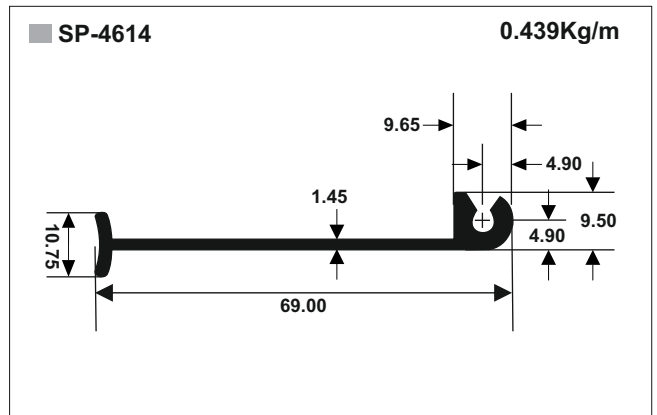
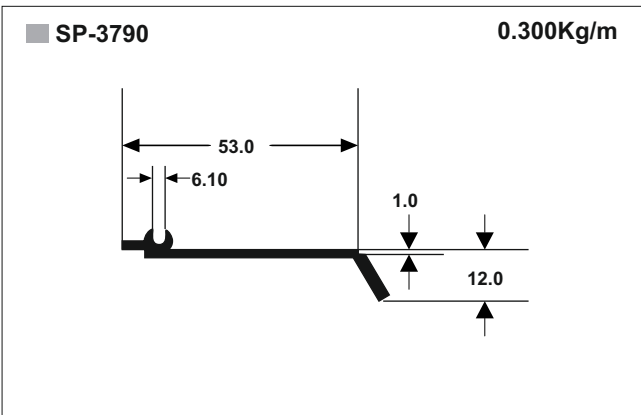
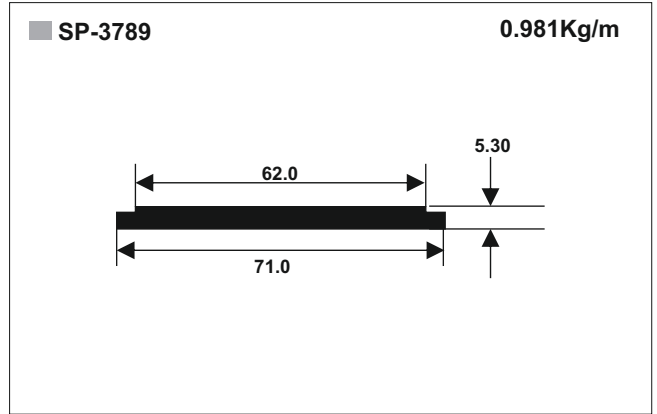
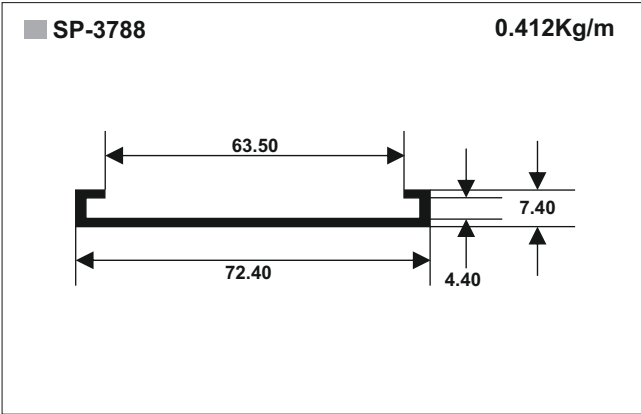

Magnifying Glass

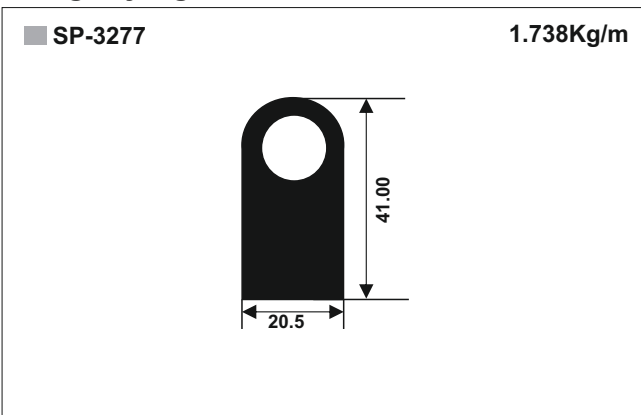



Milk Can Base

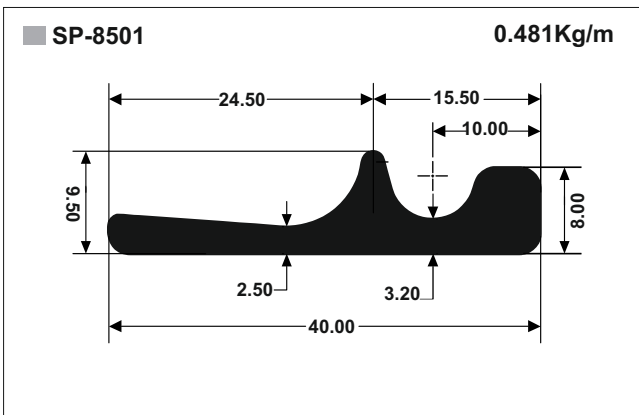
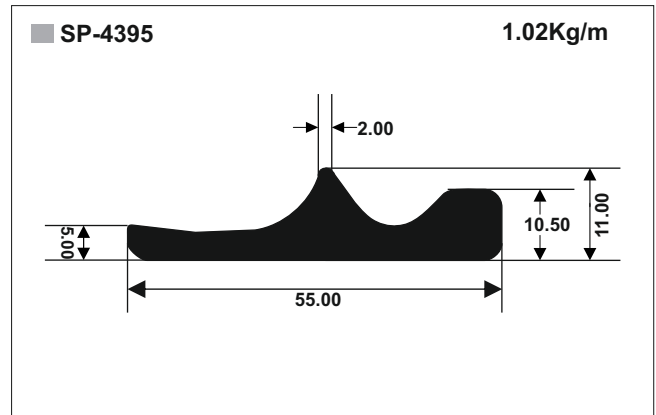
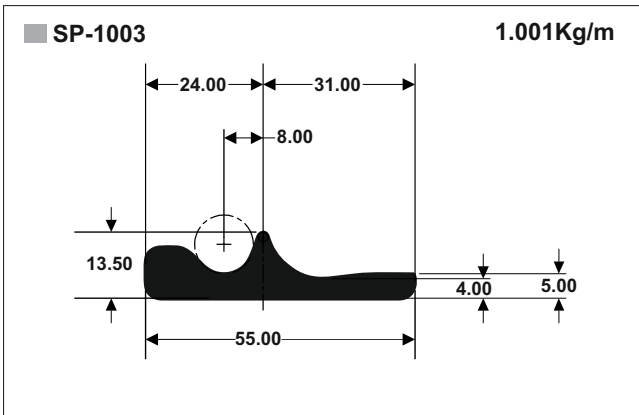

Medical Equipment

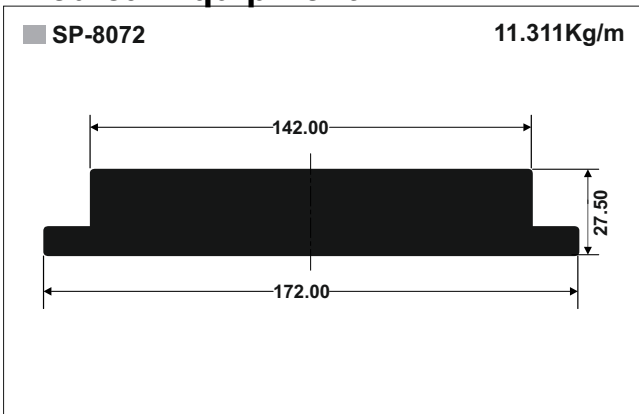

Cassette Player

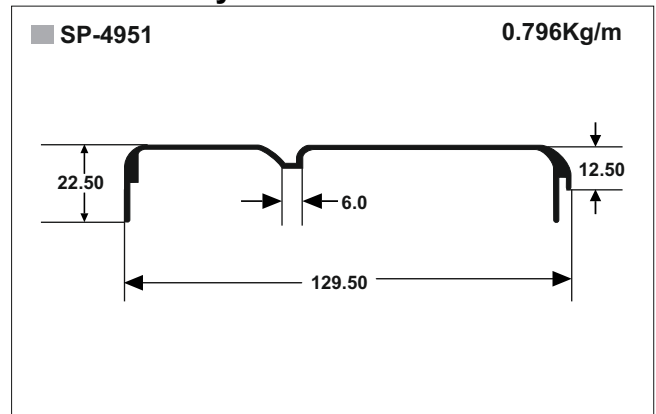





Poultry Channels

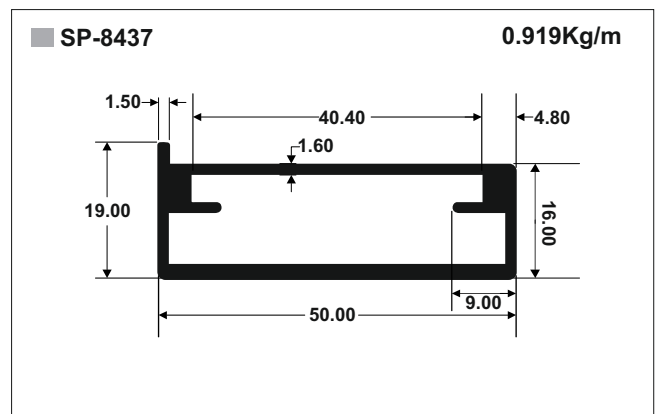
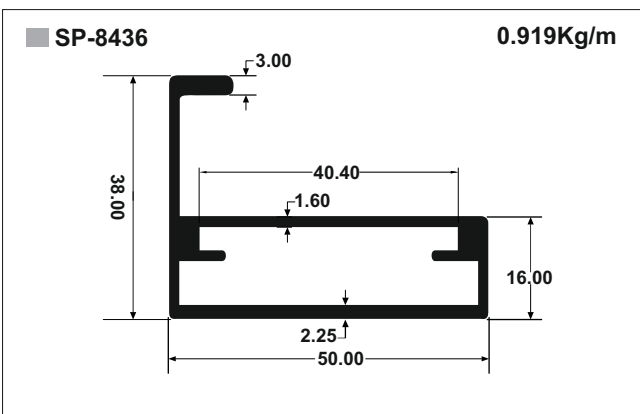
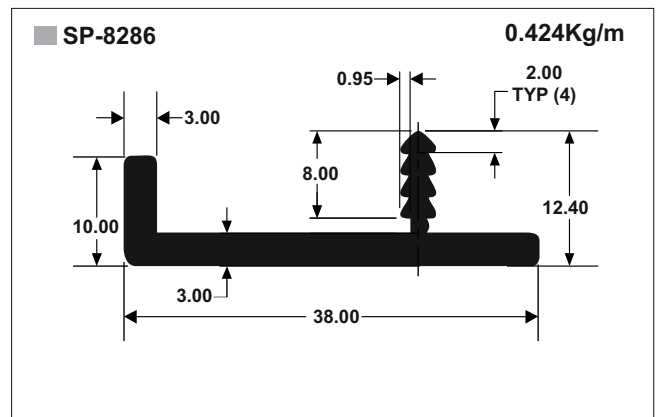
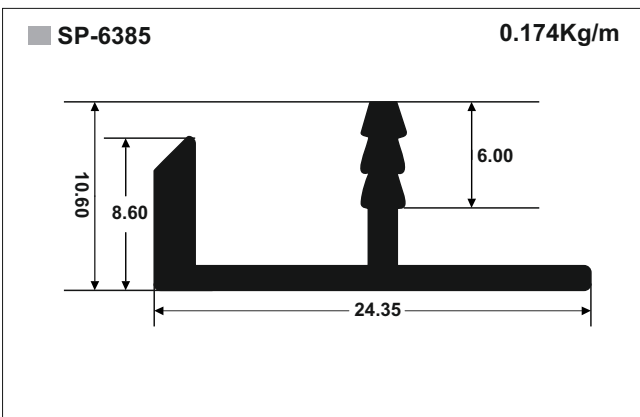
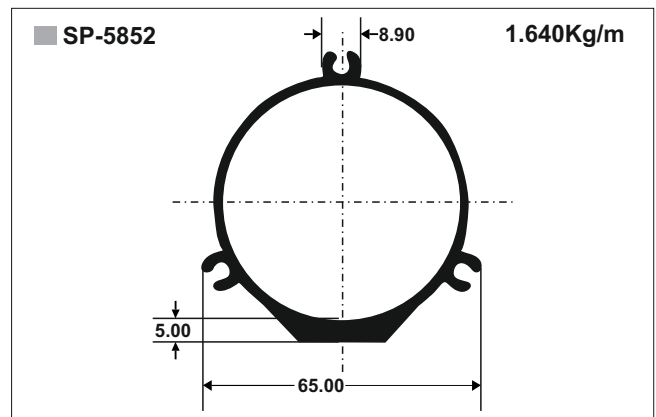
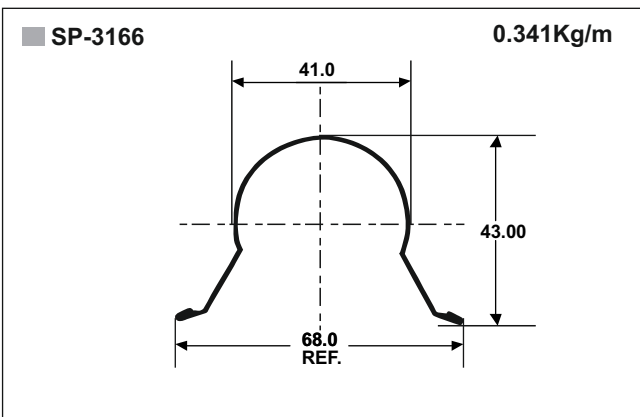
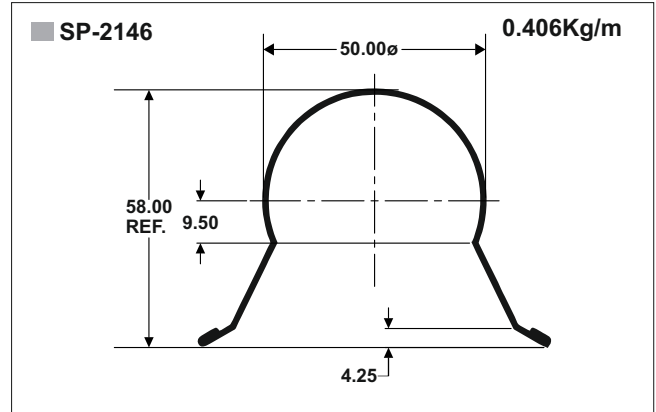
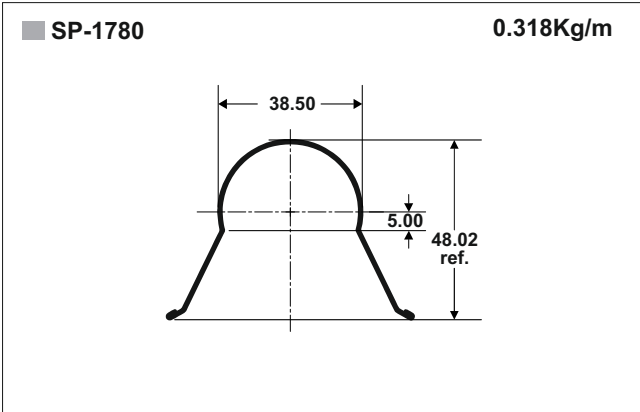



### Poultry Channels

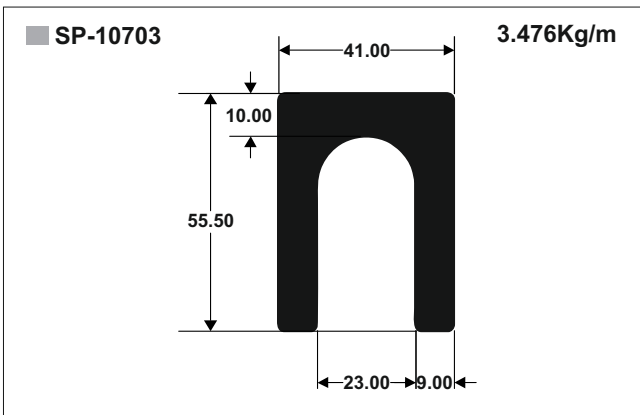
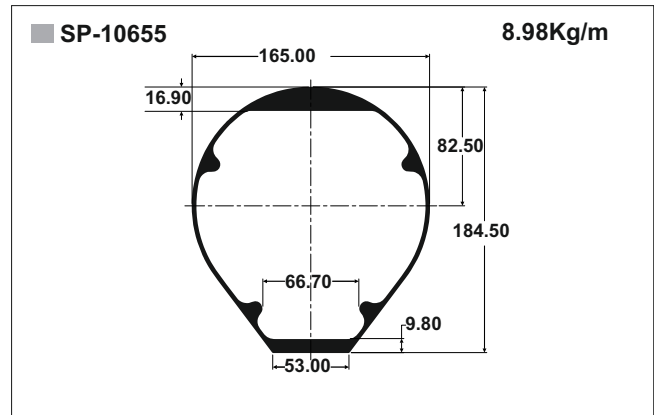
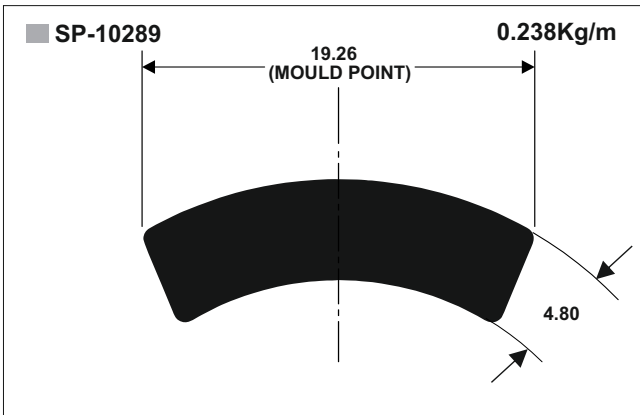

### Sports Goods

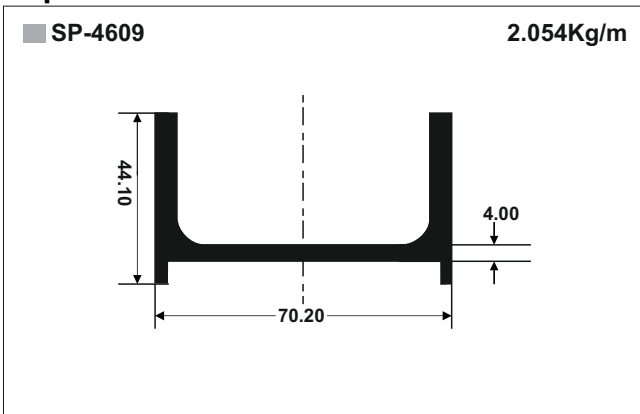

### Refrigerator Part

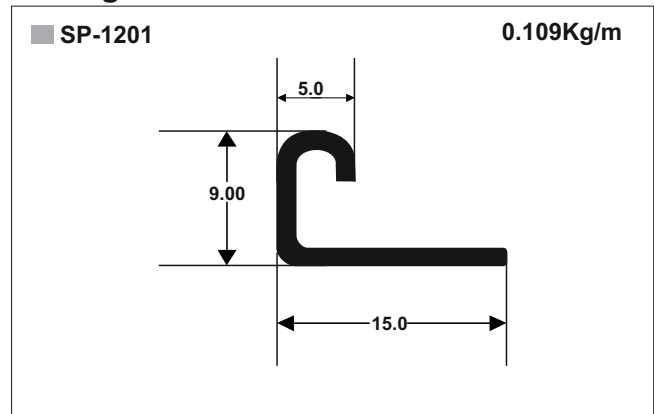



### Telescopic Tubes

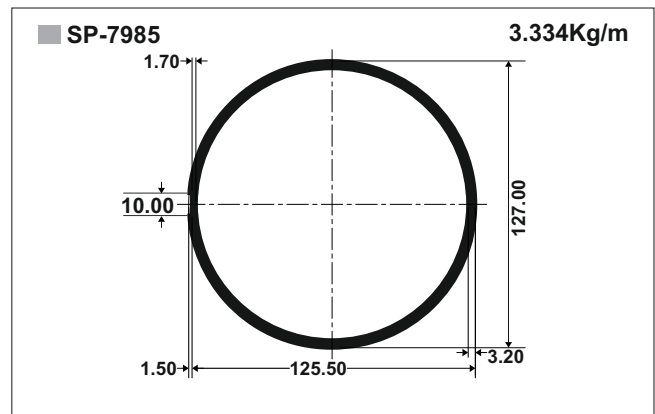
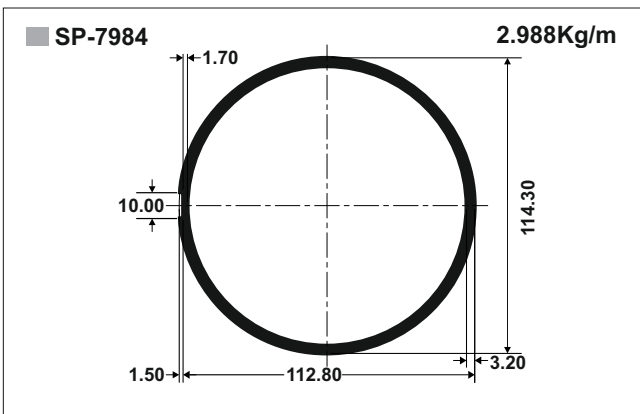
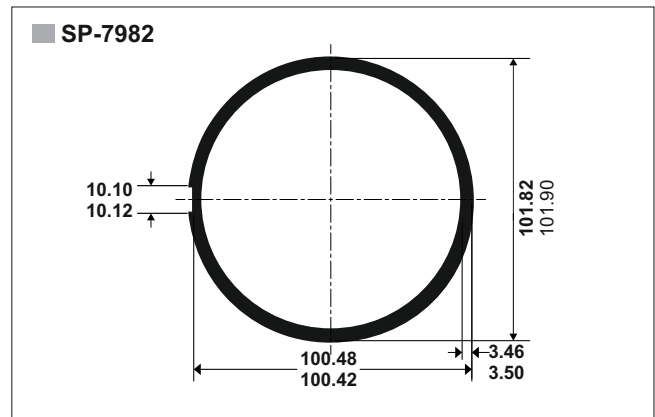
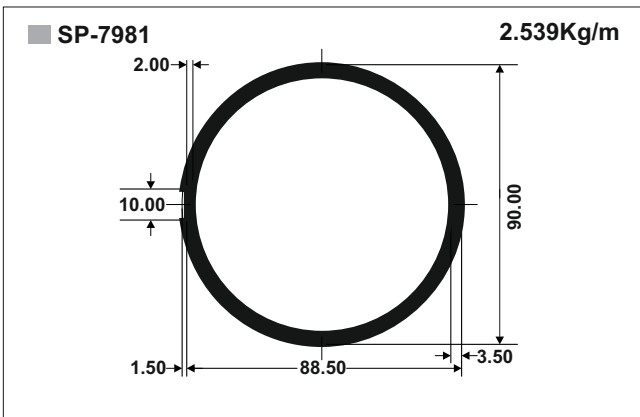
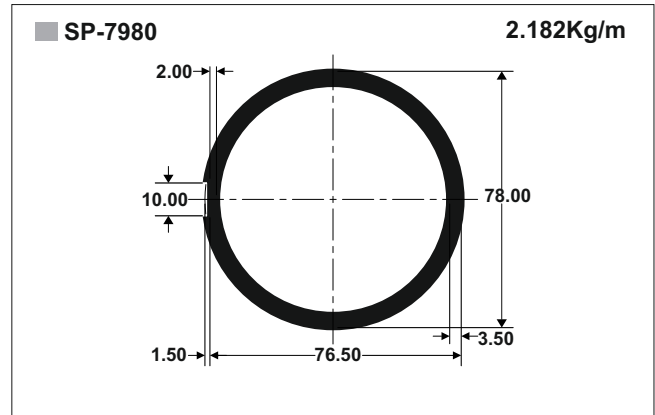
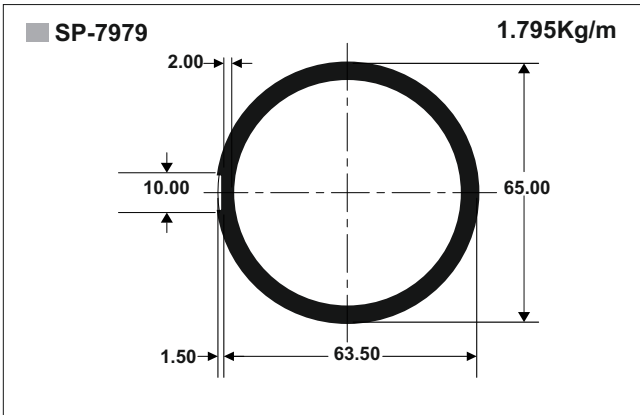



## Index

<u>Sec</u>	<u>Page</u>	<u>Sec</u>	<u>Page</u>	<u>Sec</u>	<u>Page</u>				
1003	24	4714	12	8968	21				
1118	19	4717	12	8991	16				
1119	19	4718	12	10573	16				
1201	26	4808	17	10655	26				
1301	15	4809	18	10659	16				
1658	15	4869	22	10703	26				
1718	22	4870	22	10736	15				
1719	22	4951	24	10737	15				
1780	25	5275	17	10945	16				
2065	21	5852	25	11108	19				
2066	21	6075	13	11116	17				
2071	18	6076	13	11117	17				
2072	18	6077	13	11118	19				
2074	21	6078	13						
2075	21	6193	13						
2146	25	6194	13						
2252	21	6195	13						
2253	21	6245	13						
2814	18	6286	19						
2834	18	6287	19						
3148	15	6385	25						
3166	25	6402	14						
3277	23	6403	14						
3454	15	6422	14						
3523	18	6561	20						
3608	18	6692	16						
3737	22	6738	20						
3738	22	7979	27						
3749	12	7980	27						
3788	23	7981	27						
3789	23	7982	27						
3790	23	7984	27						
3799	20	7985	27						
3980	20	8072	24						
4058	12	8100	19						
4218	15	8286	25						
4238	12	8436	25						
4395	24	8437	25						
4591	17	8501	24						
4592	17	8564	16						
4595	17	8610	14						
4609	26	8611	14						
4614	23	8612	14						
4615	23	8613	14						
4664	22	8614	14						
4665	22	8825	16						
4677	23	8920	21						



## MARKETING HEAD OFFICE

6th & 7th Floor, Birla Centurion,  
Pandurang Budhkar Marg,  
Worli, Mumbai 400030  
Tel : +91-22-6662 6666 / 6662 6609 / 6643  
Fax : +91-22-2422 7586 / 2436 2516  
Email : rajendra.pareek@adityabirla.com

## EXPORTS OFFICE

7th Floor, Birla Centurion,  
Pandurang Budhkar Marg,  
Worli, Mumbai 400030  
Tel : +91-22-6662 6666 / 6662 6630 / 6646  
Fax : +91-22-2422 7586 / 2436 2516  
Email : manoj.randive@adityabirla.com

## WORKS

P.O. Renukoot, Dist Sonbhadra,  
Uttar Pradesh - 231 217, India  
Tel. : +91-5446-252 079 / 78  
Fax : +91-5446-252 107 / 252 427  
Email : sanjeev.singh@adityabirla.com

P.B. No. 21 Alupuram, Kalamassery,  
Kerala - 683 104, India  
Tel.: +91 - 484 - 293 2446  
Fax : +91 - 484 - 254 1887  
Email : r.sivaramakrishan@adityabirla.com

## REGIONAL OFFICES

### North

Mindmill Corporate Tower  
24a, Film City  
Sec- 16 A,  
Noida - 201301.up.  
Ph. + 91120 6692100  
Fax. 91120 6692105  
Email : nutan.singh@adityabirla.com

### West

1st floor, Ahura Centre,  
82, Mahakali Caves Road, Andheri (East),  
Mumbai - 400 093, Maharashtra  
Tel.: +91-22-6691 7000 / 7031  
Fax : +91-22-6691 7070 / 7050  
Email : ashish.nema@adityabirla.com

### East

Jeevan Deep Building, 1,  
Prafulla Chandra Sen Sarani,  
Kolkata - 700 071, West Bengal  
Tel.: +91-33-2280 9710, 2288 6135  
Fax : +91-33-2288 6139  
Email : abhijit.chakraborty@adityabirla.com

### South

7th Floor, Industry house,  
45 Race Course road,  
Bengaluru - 560 001, Karnataka  
Tel.: +91-80-4041 6000  
Fax : +91-80-4041 6060  
Email : ashok.k.kumar@adityabirla.com

## AREA OFFICES

### Kochi

P.B. No. 21 Alupuram, Kalamassery,  
Kerala - 683 104, India  
Tel.: +91-484-293 2445  
Fax : +91-484-254 1887  
Email : vivek.jacob@adityabirla.com

### Chennai

Flat 2A, 2nd Floor, Appex Plaza, 3,  
Nungambakkam High Road, Chennai - 600 034  
Tel.: 91-44-2827 2333 / 2343  
Fax : 91-44-2827 4756  
Email : s.sugunaraj@adityabirla.com





[www.hindalco.com](http://www.hindalco.com)