



**HINDALCO**  
***EXTRUSIONS***

EXPERTISE IS OUR STRENGTH

**Consumer Durable - Alupuram**

*Printed Jan 2018*





**HINDALCO**  
***EXTRUSIONS***

EXPERTISE IS OUR STRENGTH



## VISION

To be a premium metals major, global in size and reach, excelling in everything we do, and creating value for our stakeholders.

## MISSION

To relentlessly pursue the creation of superior shareholder value, by exceeding customer expectation profitably, unleashing employee potential, while being a responsible corporate citizen adhering to our values.

## VALUES

**Integrity:** Honesty in every action

**Commitment:** Deliver on the promise

**Passion:** Energized action

**Seamlessness:** Boundaryless in letter and spirit

**Speed:** One step ahead always



# Hindalco Consumer Durable Catalogue

Contents	Page No.
A. Hindalco - An Overview .....	06
B. Alupuram Plant Facilities .....	07
C. Specifications .....	08
<hr/>	
1. AC Grill .....	13
2. Ladder Step .....	15
3. Ladder Hand Rail.....	18
4. Ladder .....	19
5. Miscellaneous .....	21
6. Index .....	24
7. Contacts .....	25

## **HINDALCO - An Overview**

**Hindalco Industries Limited**, a USD 15 billion flagship company of the Aditya Birla Group, is a leading producer of aluminium and copper. Hindalco is present across the value chain of Aluminium & Copper. It has global footprint spanning across 13 countries in 5 continents

### **Copper**

- World's largest single-location copper smelting capacity.
- Copper mines in Australia.

### **Aluminium**

- Amongst top 5 aluminium majors worldwide.
- World's largest aluminium rolling company.
- Integrated operations - from mines to alumina to metal to value added products
  - ✦ Ingots & redraw rods (wire rods)
  - ✦ Flat Rolled products
  - ✦ Extrusions
  - ✦ Foils

Hindalco is a leader in Aluminium Extrusions industry in India with two manufacturing facilities. Both the plants are equipped with state of the art equipment, having well established manufacturing processes and quality systems honed over five decades.

- Manufacturing Facilities
  - ✦ Renukoot, U. P. (North India)
  - ✦ Alupuram, Kerala (South India)
- Capacity 60,000 MT per annum
- Expertise in customised alloys including hard alloys
- Catering to wide range of application segments such as Architectural, Electrical, Industrial, Transport, Defence and Consumer Durable.
- Extrusions manufactured from in-house virgin metal
- Quality Certification
  - ✦ ISO 9001-2008
  - ✦ ISO 14001-2004
  - ✦ OHSAS 18001-2007

This Catalogue covers the Consumer Durable sections from the range manufactured in the Alupuram plant of Hindalco - India's first Extrusions plant started in the year 1955.

## Alupuram Plant



*1250 T Lowey Hydraulic Press with 6" container, automatic controls and puller*



*3300 T Farrel Watson Stillman Press with 9" container, automatic controls and puller*



*Ultramodern Makino Vertical Machining Centre in Die Shop*



*CNC Wire EDM Machine in Die Shop*



*Solution Heat Treatment Furnace*



*Spectrometer for Quantometric Analysis*



*Branding Machine*

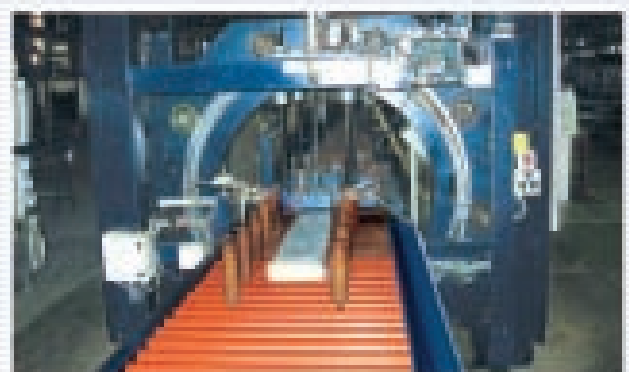

*Automated Packing Station*



TABLE - 1

**Wrought alloys: Near equivalent designations**

INDIA		U.S.A. (A.A.)	BRITAIN (B.S.)	CANADA	GERMANY (DIN)	RUSSIA	I.S.O.	FRENCH ND
NEW I.S.	OLD I.S.							
19501	1E	1050(E.C)	1E	C 1S	E-Al 99.5	-	-	-
19500	1B	1050	1B	1S	A-99.5	-	Al-99.5	1050A
24345	H15	2014	H15	B26S	AL-CU-SI	AK	-	-
24534	H14	2017	H14	17S/16S	-	D1	Al-Cu-4Mg Si	-
-	-	2024	-	24S	Al-Cu.Mg2	-	Al-Cu-4Mg 1	2024
31000	N3	3003	N3	3S	Al-Mn	A-Mn	Al-Mn 1	3003
52000	N4	5052	N4	M57S	Al-Mg.2	A-Mg	Al-Mg-2.5	5051
53000	N5	5086	N5	54S	-	A-Mg-3	Al-Mg-4	-
54300	N8	5083	N8	D54S	Al-Mg-4.5 Mn	-	Al-Mg-4.5 Mn	5083
65032	H20	6061	H20	65S	Al-Mg-Si Cu	-	Al-Mg-1Si Cu	-
63400	H9	6063	H9	50S	Al-Mg-Si 0.5	-	Al-Mg Si	-
64430	H30	6351	H30	B51S	Al-Mg-Si 1	AV	Al-Si-1 Mg	6081
64423	H11	6066	H11	C62S	-	-	-	-
62400	-	6005	-	C51S	-	-	-	-
63401	91E	6101	91E	D50S	E.Al.Mg.Si 0.5	-	-	-
64401	-	6201	-	-	-	-	-	-
74530	-	7039	-	D74S	Al-Zn-Mg.1	-	-	3004
-	-	7075	DTD 5124	75S	Al-Zn-Mg Cu 1.5	-	Al-Zn 6 Mg Cu	7075





TABLE - 2

**Wrought alloys: Guide to selection**

Alloy	Temper	Resistance to Corrosion	Workability (Cold)	Machinability	Brazeability	Weldability	Commonly available forms	Indications of use
EC/1050, 1060 (1B) (19501) (19500) (19600)	F, O	A	A	D	A	A	Flats, Rods, Tubes & other section	Electrical conductors, cable sheathing, impact-extruded products, pressing utilities of anodizing quality, pen caps, piping etc.
1100 (1C) (19000)	F, O	A	A	D	A	A	Flats, Rods, Tubes & other section	Packaging lightly stresses and decorative assemblies in architecture and transport, equipment for chemical, food and brewing industries.
2014 (H 15) (24345)	T4 T6	C C	C D	B B	D D	C C	Rods & Bars Rods & Bars	Highly stressed component of all types in aircraft, ordnance and general engineering.
2017 (H 14) (24534)	T4	C	C	B	D	C	Rods & Bars	Highly stressed parts in aircraft and other structures, screw machine products.
2024	T4	C	C	B	D	C	Rods & Bars	Load Cell, Highly stressed component of all types in aircraft, ordnance and general engineering.
4043 (N 21) (43000)	F, O	A	A	D	A	A	Rods & other sections	Welding wire, architectural applications
5005 (52000A)	O, F	A	A	D	B	A	Flats, Rods, other sections	Structures exposed to marine attractive anodized finish, architectural, electrical conductors etc.
5052 (N 4)	O, F	A	A	D	C	A	Flats, Rods, Tubes & other sections	Structures exposed to marine atmosphere, aircraft parts, wire rope ferrules, rivet stock.
5086 (N 5) (53000)	O, F	A	A	D	D	A	Flats, Rods & other sections	Ship building and other marine applications, rivets, coinage etc.
5056 (N 6) (55000)	O, F	A	A	D	D	A	Rods	Zips, Welding Rods and Rivets.
6061 (H 20) (65032)	O, F T4 T6	A A A	A C D	D C C	A A A	A A A	Rods, Flats, Tubes & other sections	Heavy duty structures, building hardware, sections for bus body, truck and rail coach, furniture, rivets etc.
6063 (H9) (63400)	O, F T4 T6 T5	A A A A	A B C C	D C C C	A A A A	A A A A	Rods, Flats, Tubes & other sections	Building hardware, architectural section with good surface finish, medium strength furniture and anodized sections.



**TABLE - 2**

## Wrought alloys: Guide to selection

Alloy	Temper	Resistance to Corrosion	Workability (Cold)	Machinability	Brazeability	Weldability	Commonly available forms	Indications of use
6066 (64423)	O, F T4 T6	B B B	B C C	D B B	A A A	A A A	Rods and other solid sections	For welded structures, textile parts, heavy duty machine parts.
6101 (91 E) (63401)	T4 T6	A A	B B	C C	A A	A A	Rods, Flats, Tubes & other sections	High strength electrical busbar sections.
6201 (64401)	T4	A	A	C	A	A	Redraw Rod	Overhead conductors, ACAR and AAAC
6351 (H 30) (64430)	O, F T4 T6	A A A	A C D	D C C	A A A	A A A	Rods, Flats, Tubes & other sections	Structural and general engineering items such as rail & road transport vehicles, bridges, cranes, roof trusses, rivets etc.
7039 (D74S) (74530)	O, F T4 T6	A A A	A C D	D C C	A A A	A A A	Flats, Tubes, Rods & other sections	Defence structures like mobile bridges etc. Tread and chequered plates, Excellent welding property with no loss of strength in welded zone.
7075 (DTD5124)	O, F T4 T6	A A A	A A D	A A A	A A A	A A A	Rods	Highly stressed structural applications

### Notes:

- Relative ratings for corrosion, workability and machinability in decreasing order of merit A, B, C and D.
- Weldability & brazeability ratings A, B, C and D are relative ratings defined as follows:
  - Generally weldable by the commercial procedure & methods.
  - Weldable with special technique.
  - Limited weldability due to crack sensitivity or loss in corrosion resistance and mechanical properties.
  - Generally not weldable.
- Availability of other forms subject to special enquiries and methods.



TABLE - 3

**Wrought alloys: Chemical composition limits (percent)**

Alloy (ISS) Old	New	Equivalent alloy (AA) U.S.A.	Copper		Magnesium		Silicon		Iron Max.	Manganese		*Others (Total) Max.	Remarks
			Min.	Max.	Min.	Max.	Min.	Max.		Min.	Max.		
1C	19000	1100	-	0.10	-	-	-	0.5	0.6	-	0.1	0.1	Aluminium 99.0% Min
1 B	19500	1050	-	0.05	-	-	-	0.25	0.4	-	0.05	0.1	Aluminium 99.5% Min
1 E	19501	-	-	0.04	-	-	-	0.15	0.35	-	0.03	0.1	Aluminium 99.5% Min
-	19600	1060	-	0.05	-	-	-	0.25	0.35	-	0.03	0.1	Aluminium 99.6% Min
H 15	24345	2014	3.8	5.0	0.2	0.8	0.5	1.2	0.7	0.3	1.2	0.5	-
H 14	24534	2017	3.5	4.7	0.4	1.2	0.2	0.7	0.7	0.4	1.2	0.5	-
		2024	3.8	4.9	1.2	1.8	-	0.5	0.5	0.3	0.9	0.15	Zn 0.25
N 3	91000	3003	-	0.1	-	0.1	-	0.6	0.7	1.0	1.5	0.4	-
		4032	0.8	1.3	0.8	1.3	-	13.5	0.6	-	0.2	0.15	Ni 0.8 - 1.3
N 4	52000	5052	-	0.1	1.7	2.6	-	0.6	0.5	-	0.5	0.4	Cr + Mn = 0.5
M 5	53000	5086	-	0.1	2.8	4.0	-	0.6	0.5	-	0.5	0.4	Cr + Mn = 0.5
N 8	54300	5083	-	0.1	4.0	4.9	-	0.4	0.7	0.5	1.0	0.4	Chromium up to 0.25
H 20	65032	-	0.15	0.4	0.7	1.2	0.4	0.8	0.7	0.2	0.8	0.4	**Cr = 0.15 - 0.35
-	-	6061	0.15	0.4	0.8	1.2	0.4	0.8	0.7	-	0.15	0.4	Chromium 0.04 to 0.35
H 9	63400	6063	-	0.1	0.4	0.9	0.3	0.7	0.6	-	0.3	0.4	-
-	-	6066	0.7	1.2	0.8	1.4	0.9	1.8	0.7	0.6	1.1	0.4	-
-	64423	-	0.5	1.0	0.5	1.3	0.7	1.3	0.8	-	1.0	-	-
9 1E	63401	6101	-	0.05	0.4	0.9	0.3	0.7	0.5	-	0.03	0.1	-
H 30	64430	6351	-	0.1	0.4	1.2	0.6	1.3	0.6	0.4	1.0	0.3	-
		6082	-	0.1	0.6	1.2	0.7	1.3	0.5	0.4	1.0	0.3	Chromium up to 0.25
-	74530	7039	-	0.2	1.0	1.5	-	0.4	0.7	0.2	0.7	0.4	Zinc 4.0 - 5.0 %
-	-	7075	1.2	2.0	2.1	2.9	-	0.5	0.5	-	0.3	0.2	Zinc (5.1 - 6.1) % & Chromium(0.18-0.28) %

\* Titanium and/or other grain refining elements

\*\* Either Mn or Cr shall be present



TABLE - 4

**Wrought alloys: Mechanical properties**

Heat Treatable Alloys					
Alloy A A Old (ISS) New (ISS)	Temper	Ultimate Tensile Strength Kg/mm <sup>2</sup>		0.2% Proof Stress Kg/mm <sup>2</sup>	Elongation On 50mm GL
		Min.	Max.		
2014 [H15] [24345]	T4[W]	39	-	24.0	10
	T6 [WP]	49	-	43.0	6
2017 [H14] [24534]	T4[W]	39	-	24.0	10
2024 [H9]	T4	40.5	-	26.5	12
6063 [H9] [63400]	T4[W]	14	-	8.0	14
	T6 [WP]	19	-	15.5	7
6061 [H20] 65032]	M	11.2	-	5.1	12
	T4[W]	19	-	11.5	14
	T6 [WP]	28.5	-	24.0	7
6351[H30] [64430]	M	11.2	-	8.2	12
	T4[W]	19	-	12.0	14
	T6 [WP]	31.5	-	27.5	7
6066	M	11.0	-	-	12
	T4[W]	28	-	17.5	14
	T6 [WP]	35	-	31.5	7
6101[91E] [63401]	T4[W]	14	-	8.0	12
	T6 [WP]	20.5	-	17.0	10
6201 [64401]	T4[W]	16	-	7.0	14
	T8 [WDP]	32	-	-	3
7039 [74530]	T4[W]	28	-	23.5	9
	T6 [WP]	31.5	-	26.5	7
7075	T6 [WP]	54	-	46.5	6

Properties indicated herein are typical properties and are given for information only. However properties of all the profiles in specific alloy shall be as per I. S. Specification.



# AC GRILL

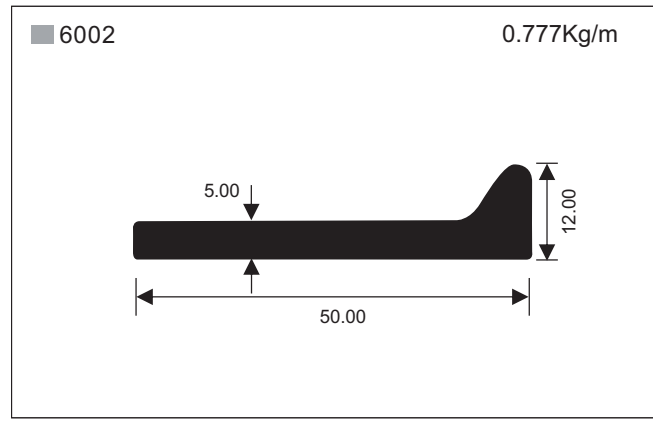
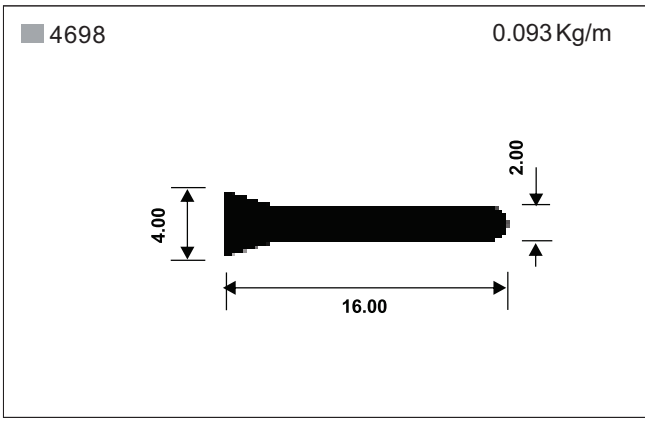
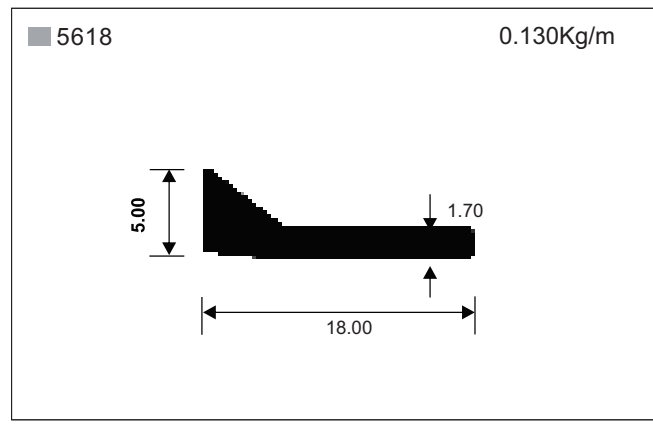
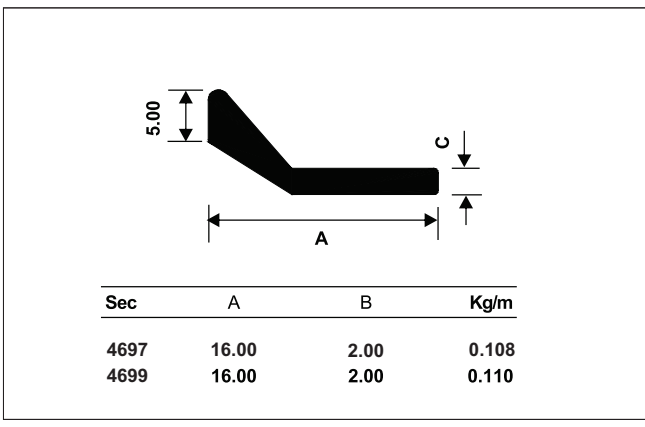
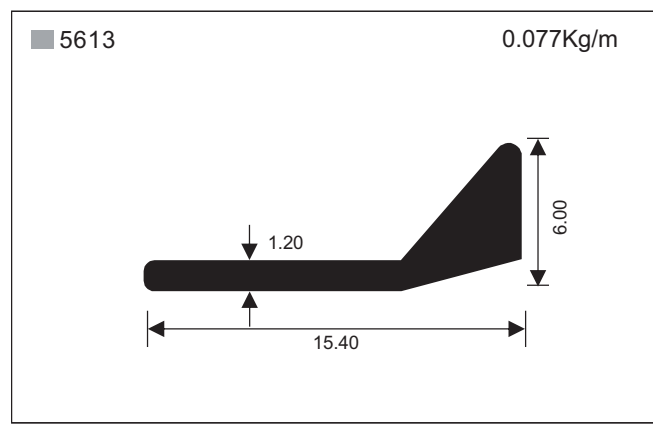
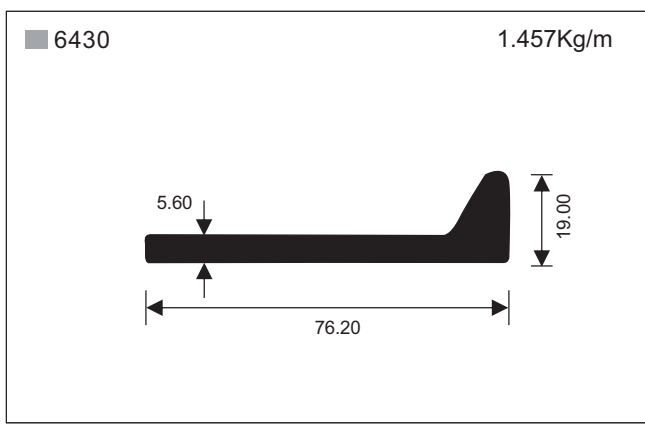
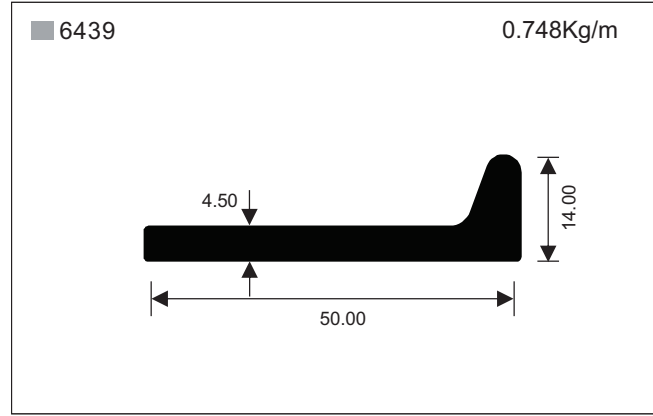
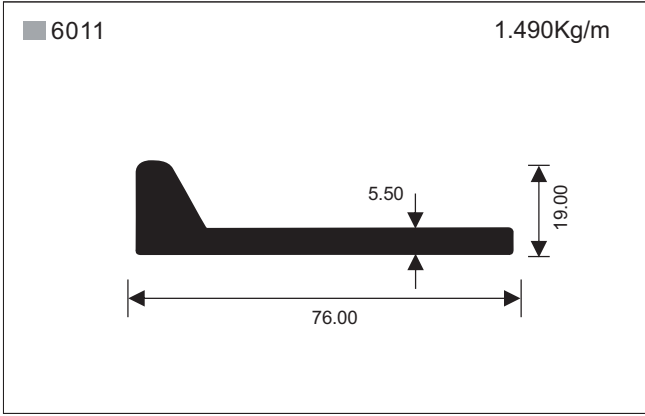



# AC GRILL

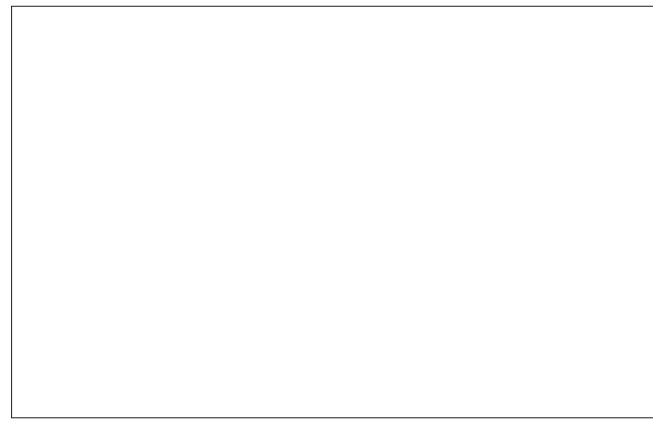
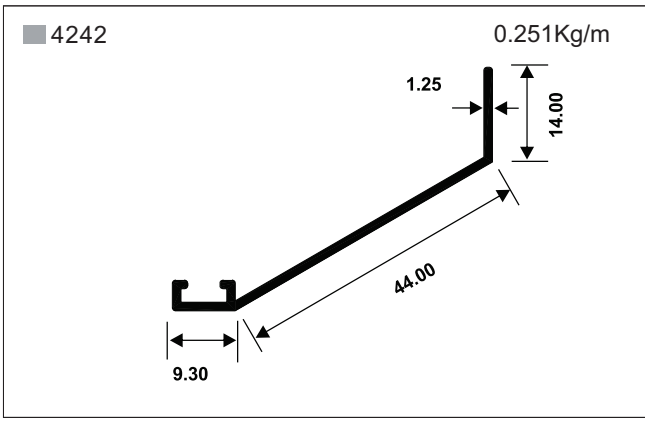
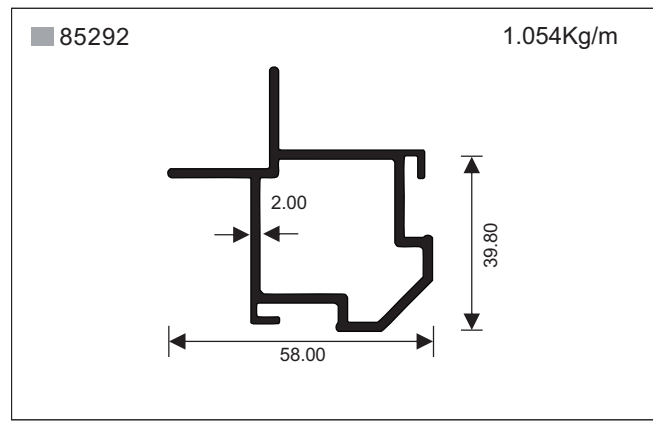
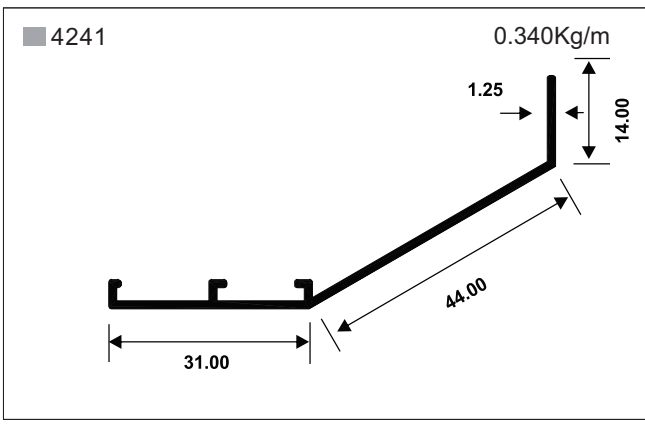
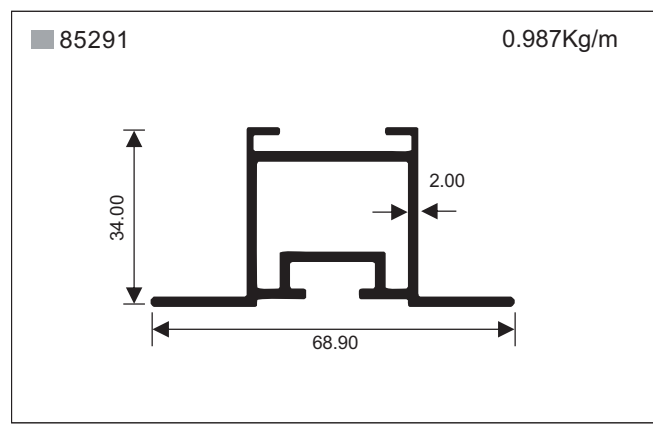
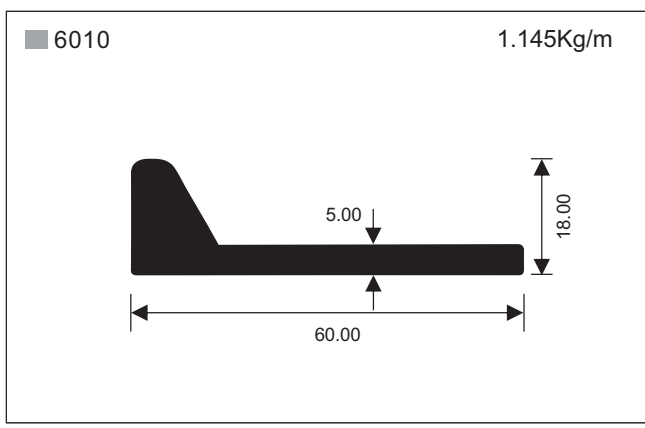
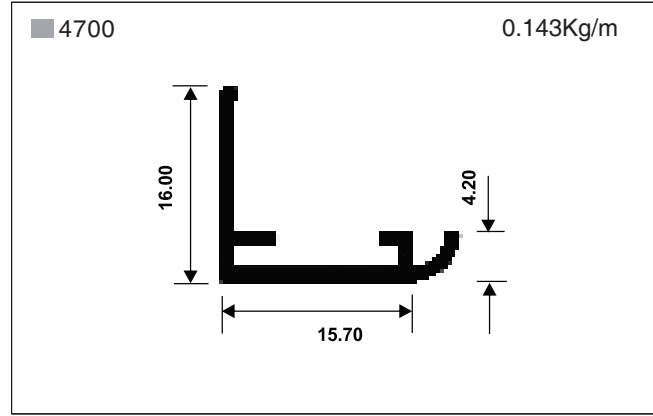
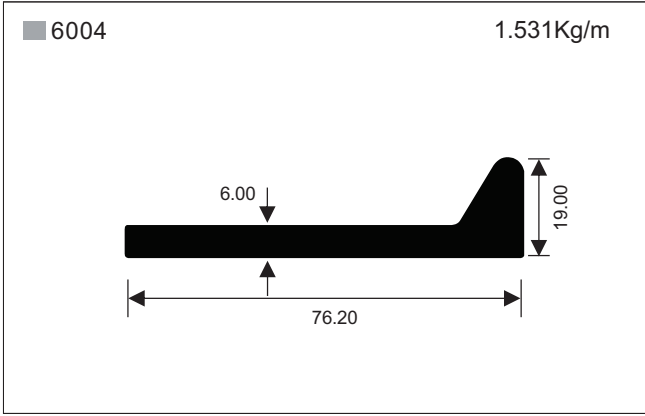



# LADDER STEP

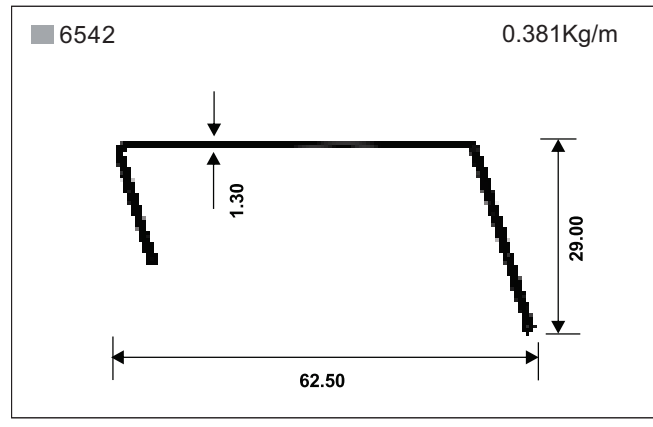
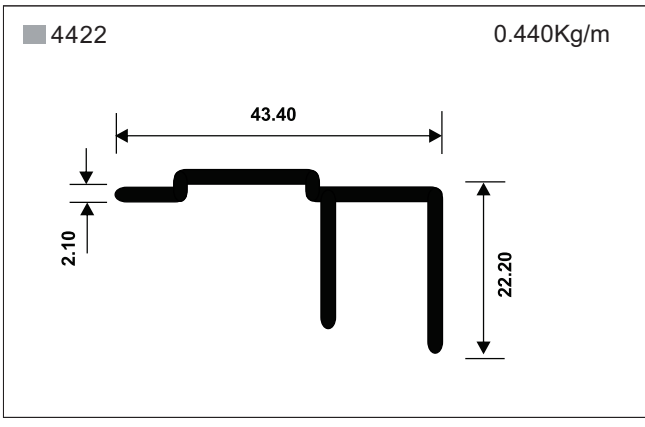
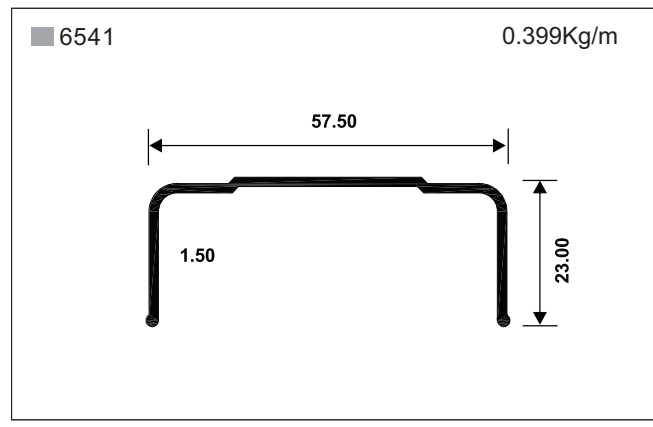
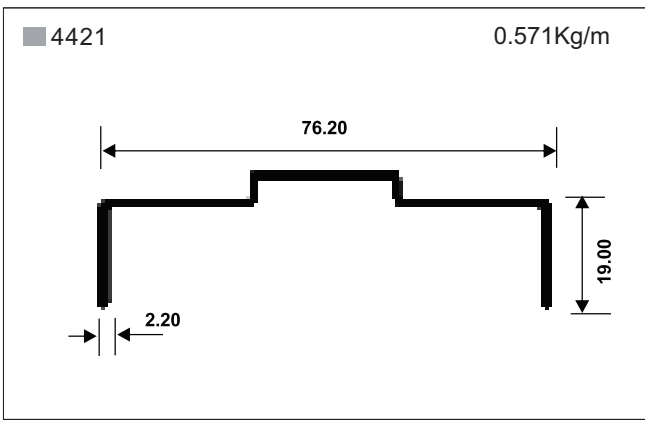
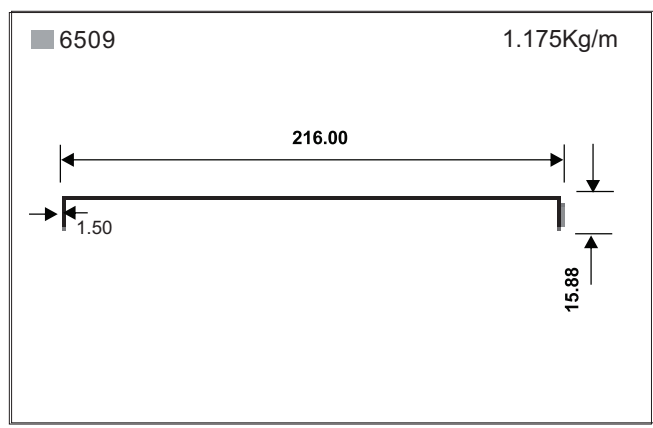
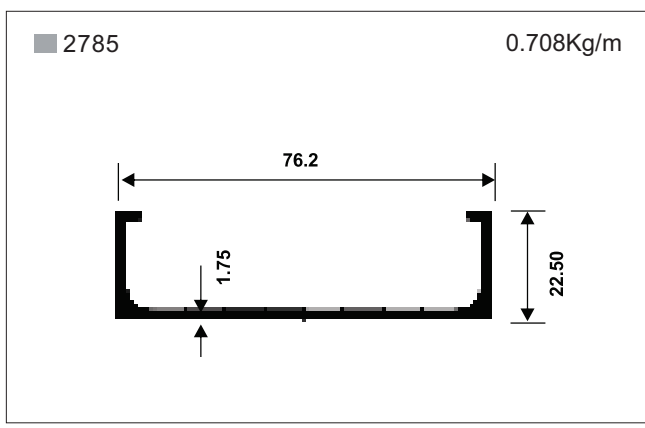
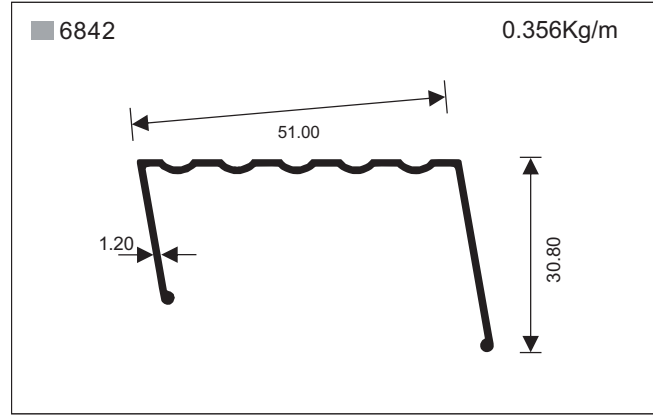
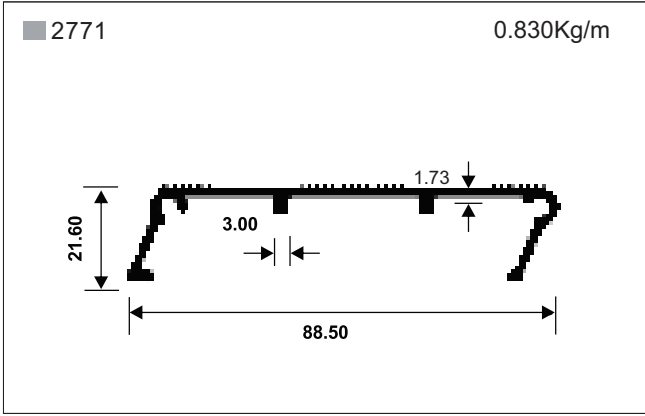



# LADDER STEP

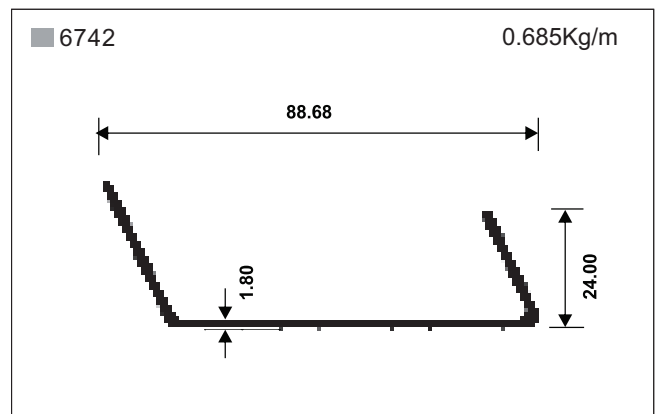
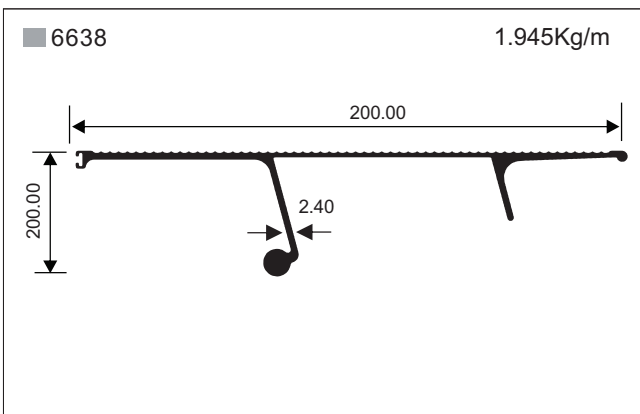
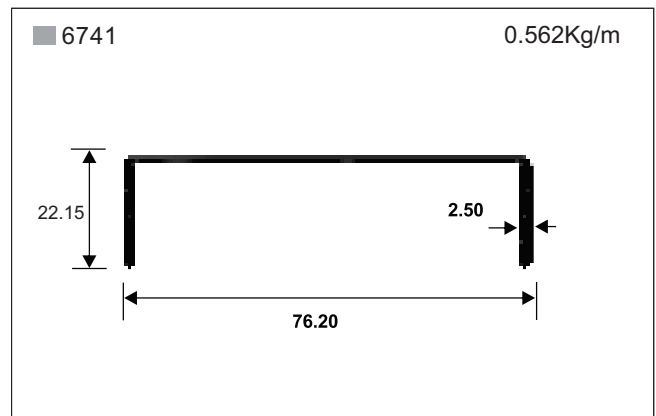
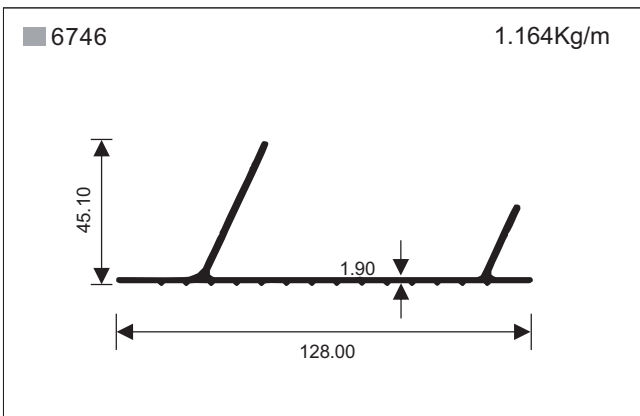
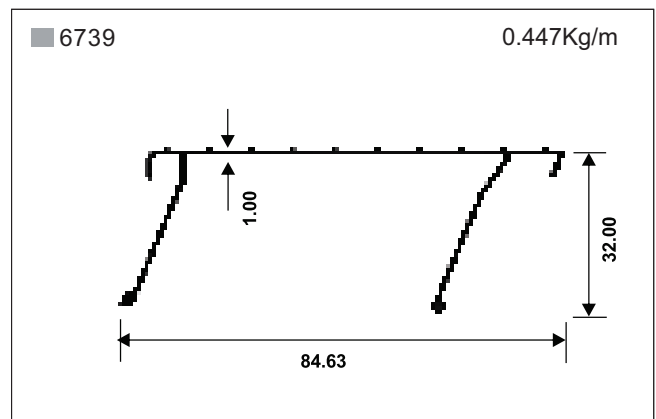
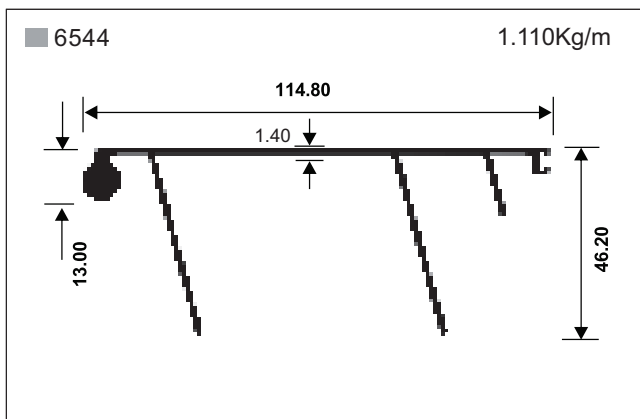
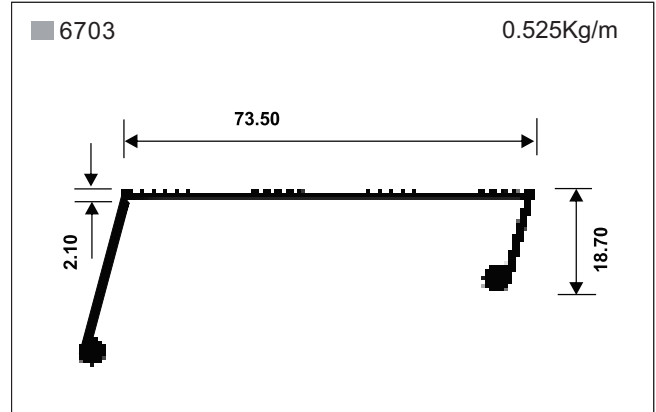
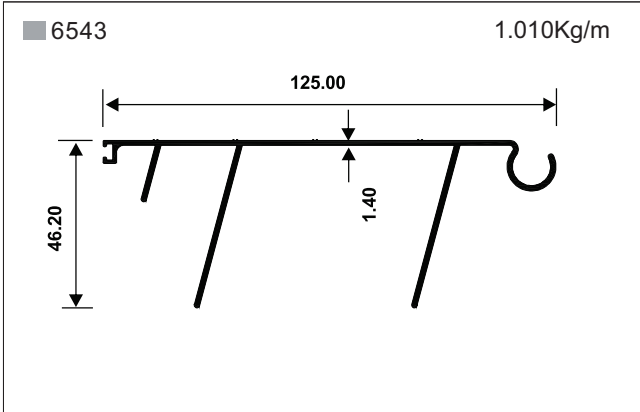





# LADDER STEP

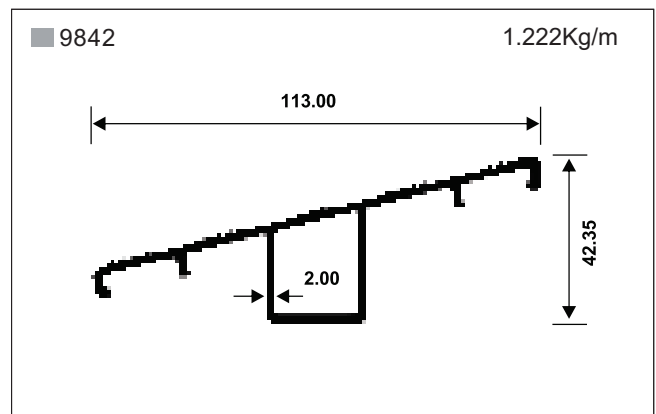
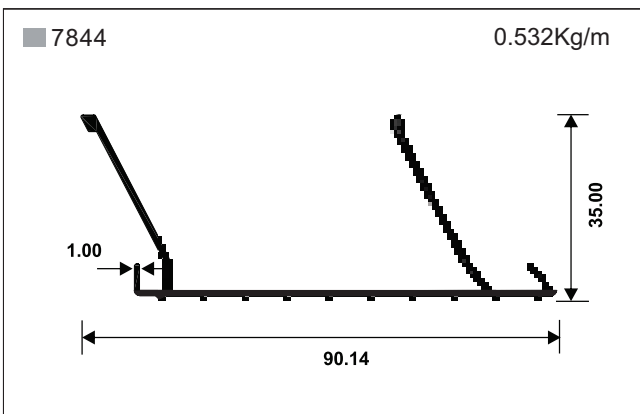
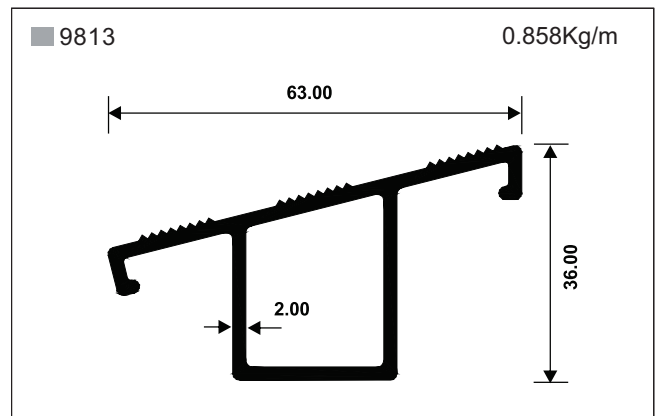
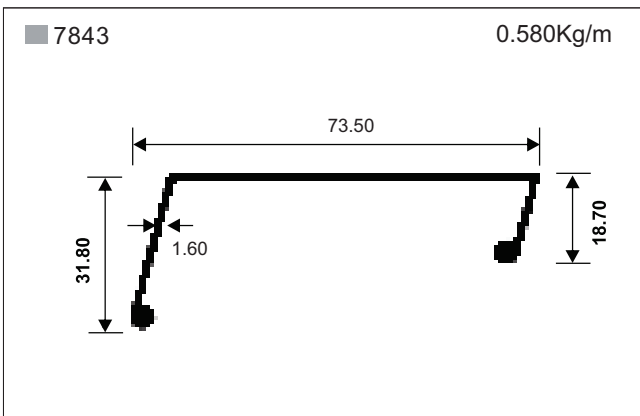
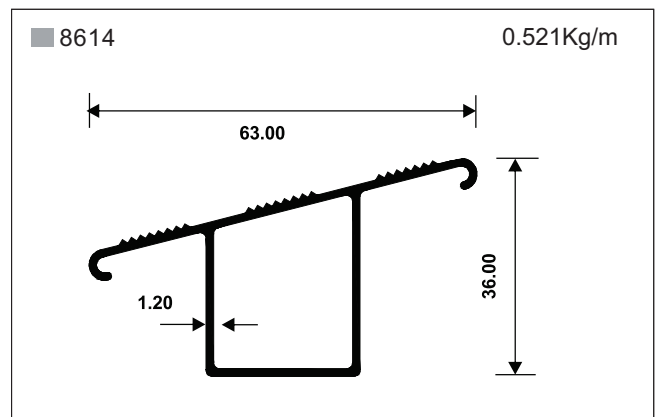
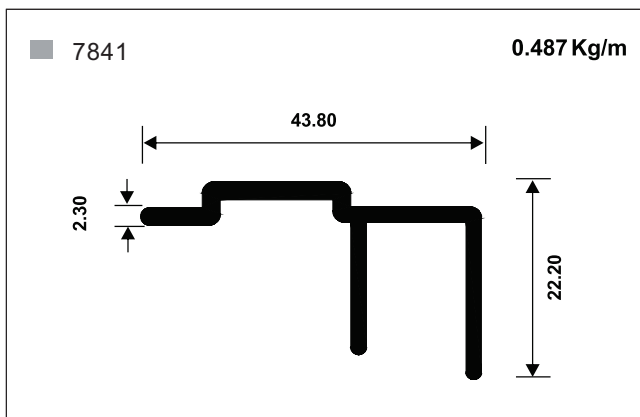
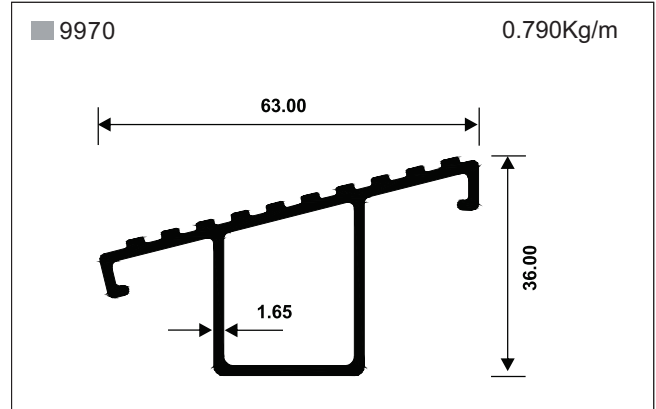
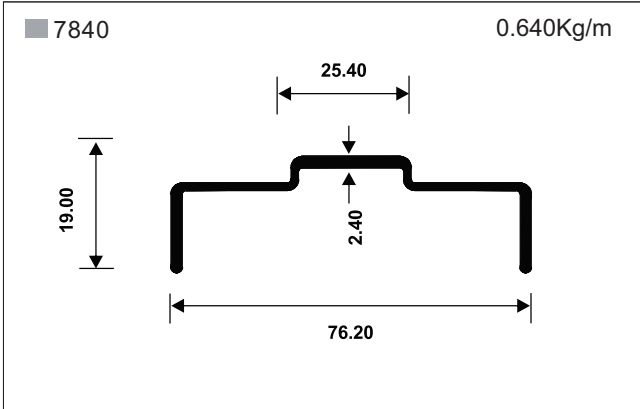



# LADDER HAND RAIL

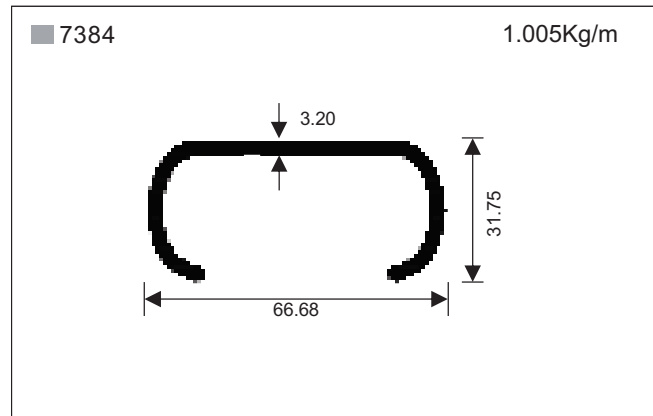
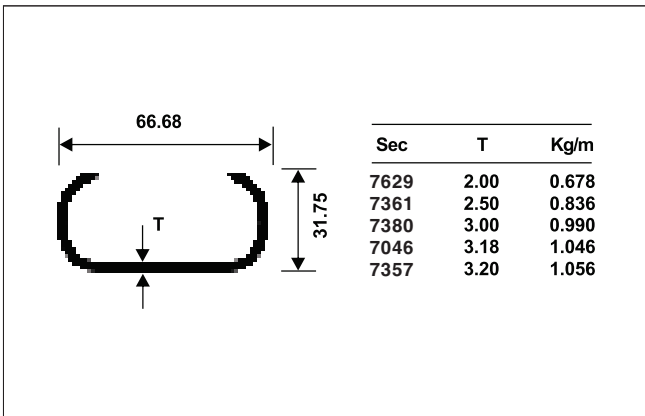
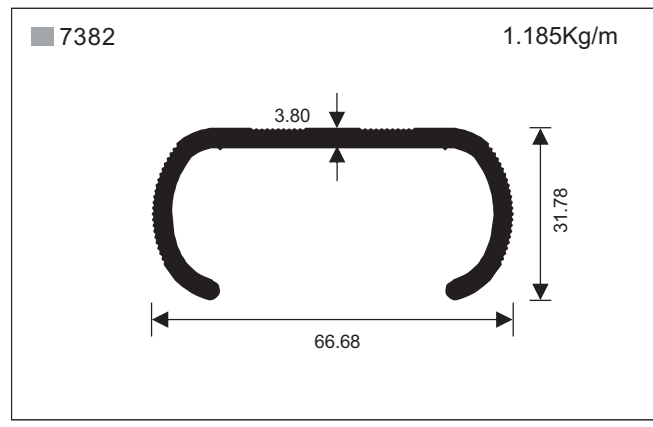
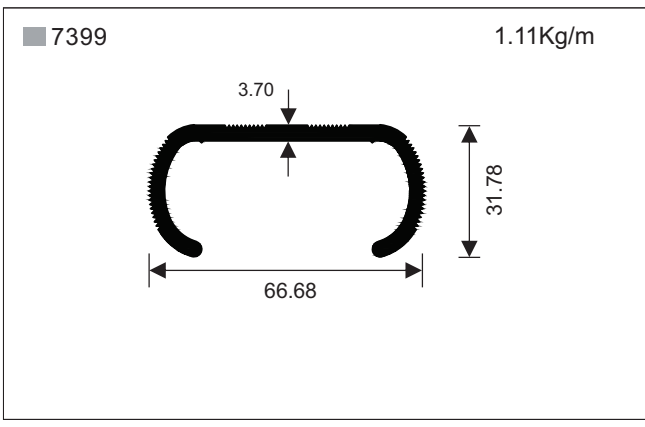
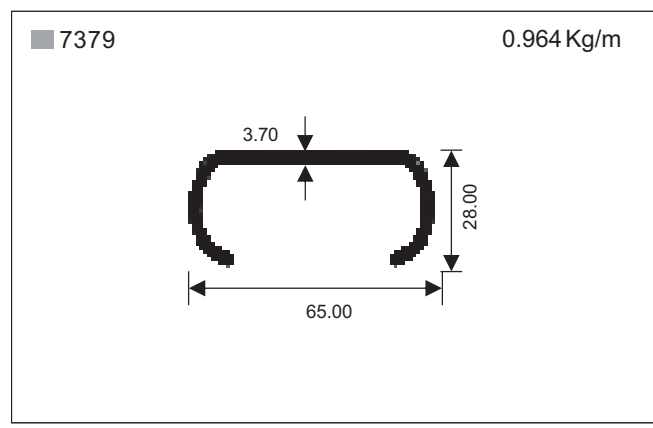
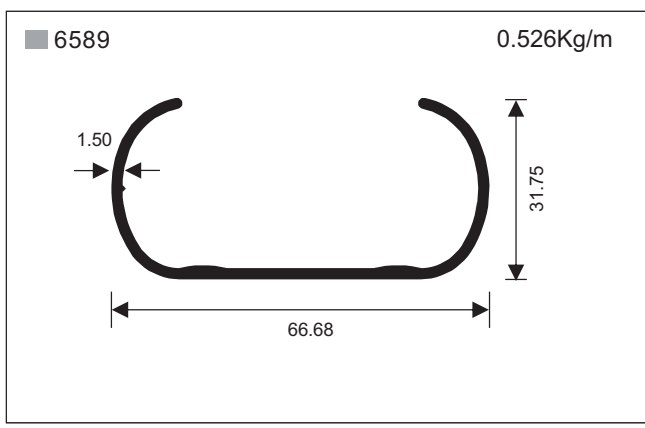
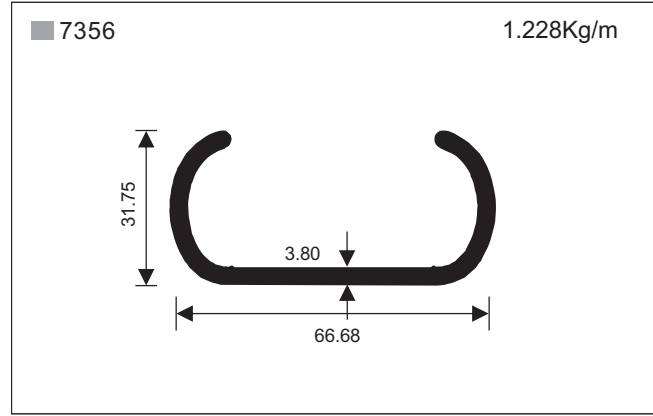
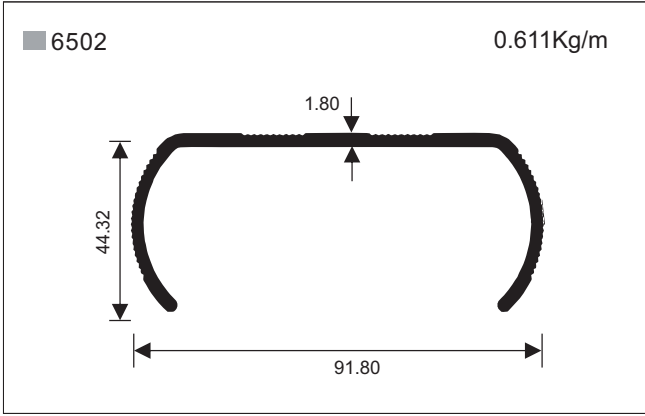



# LADDER

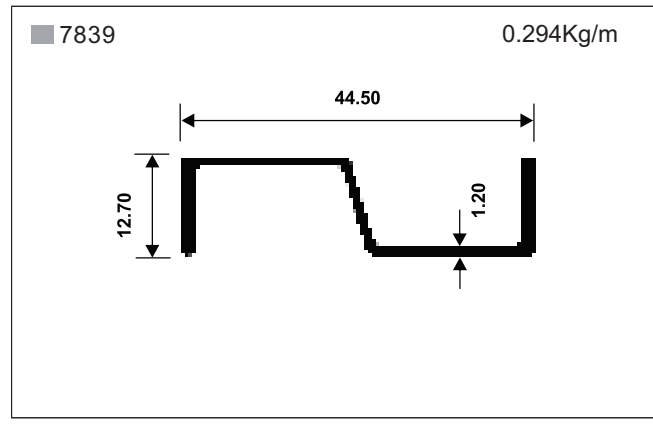
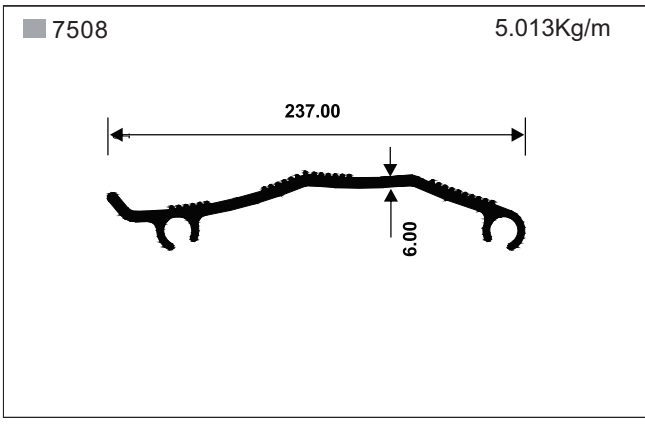
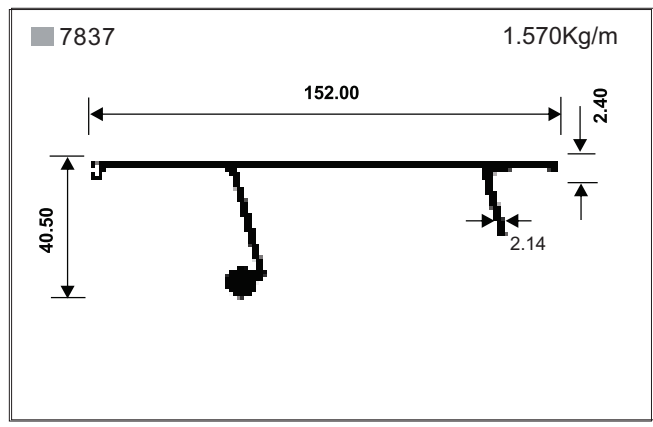
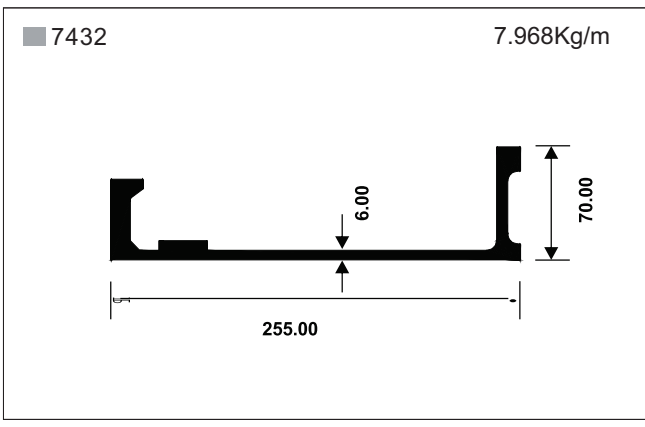
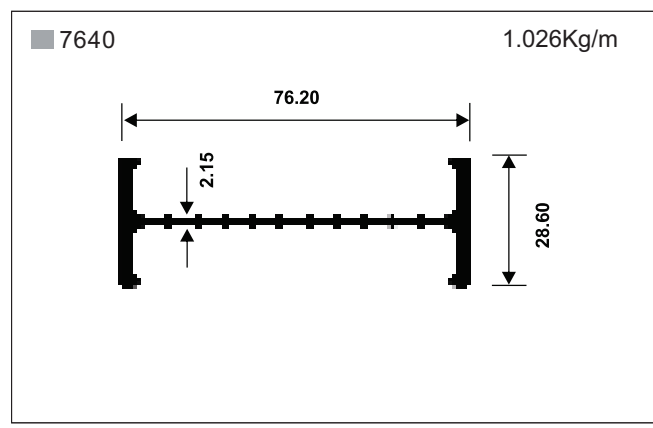
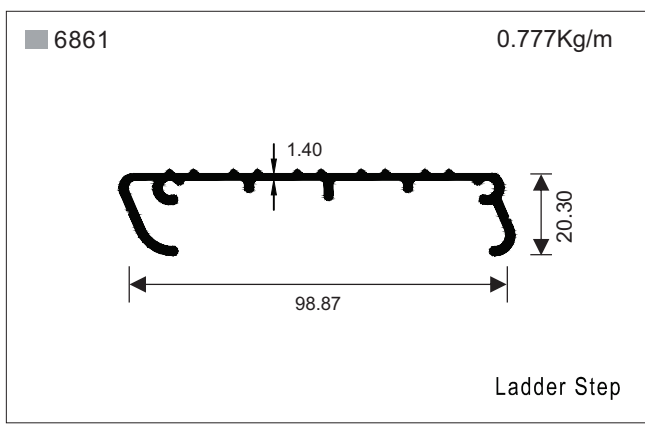
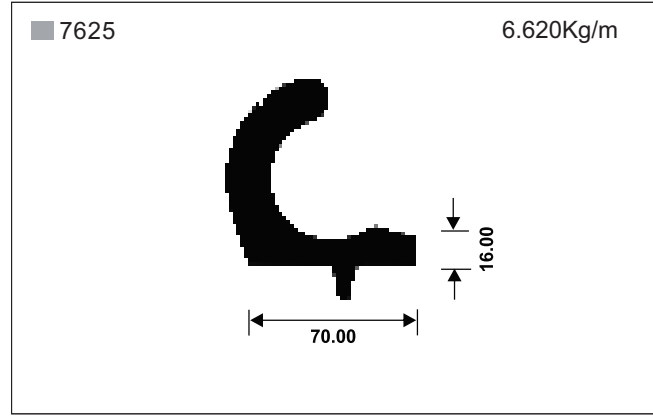
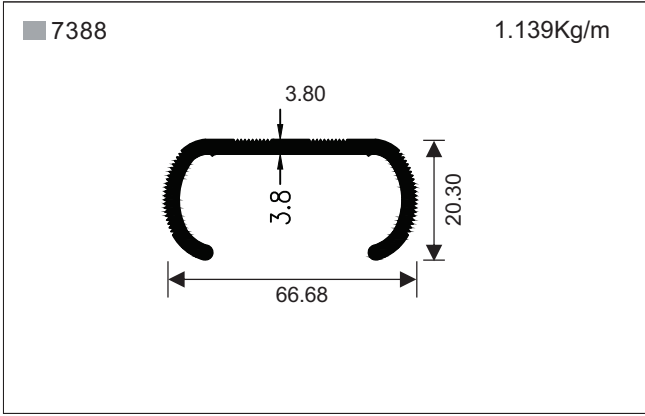



# LADDER

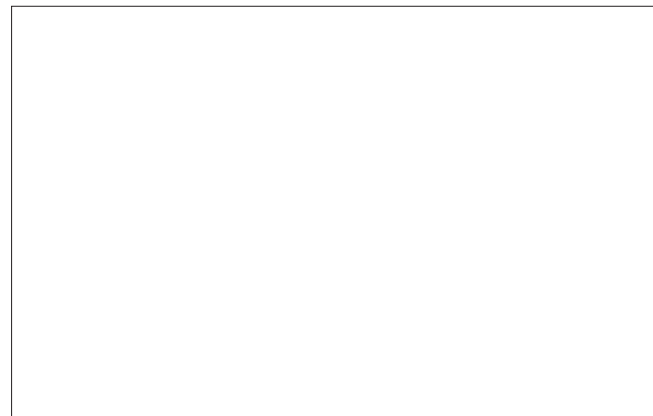
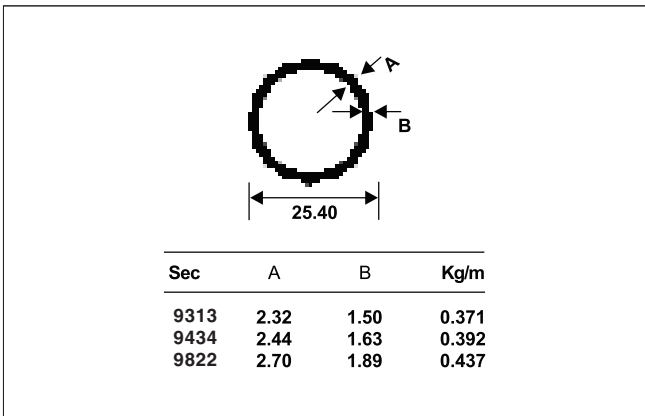
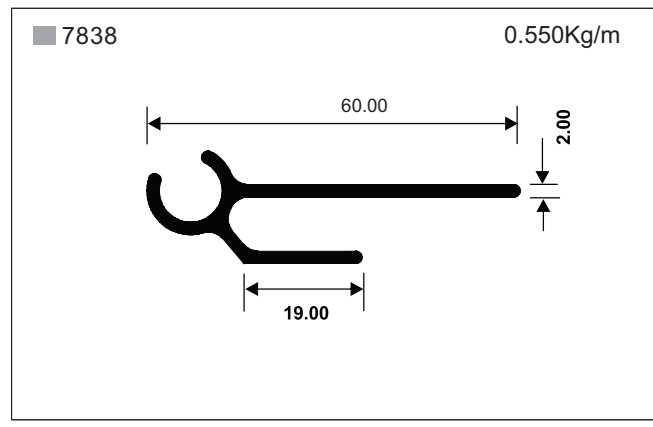
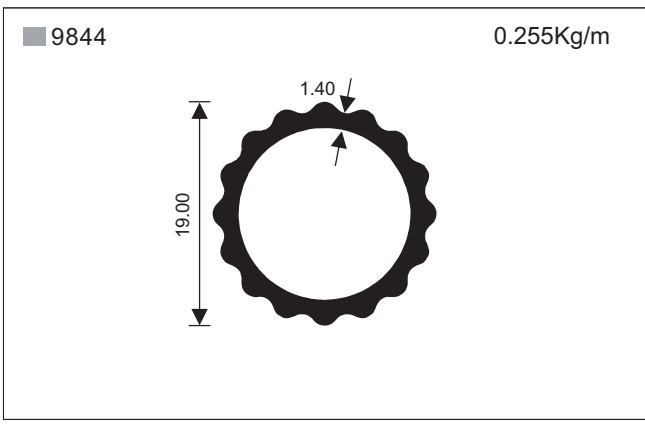
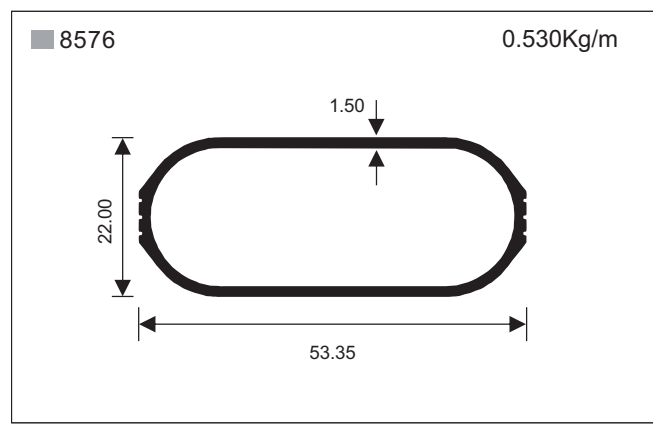
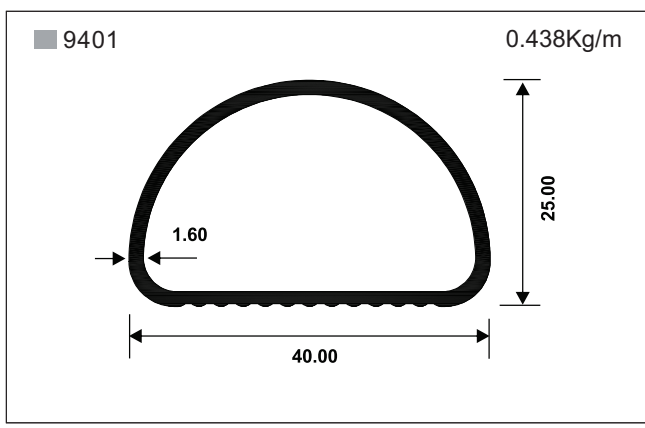
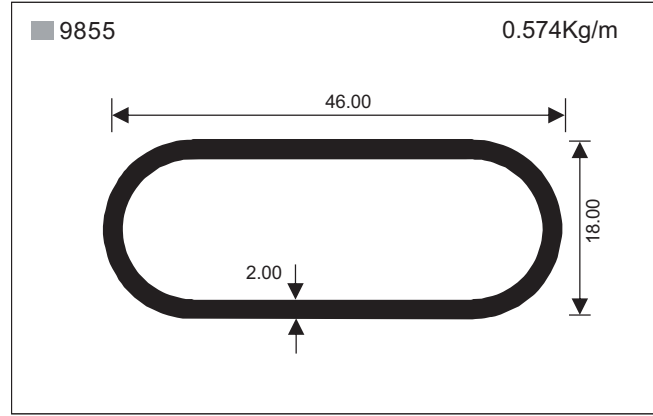
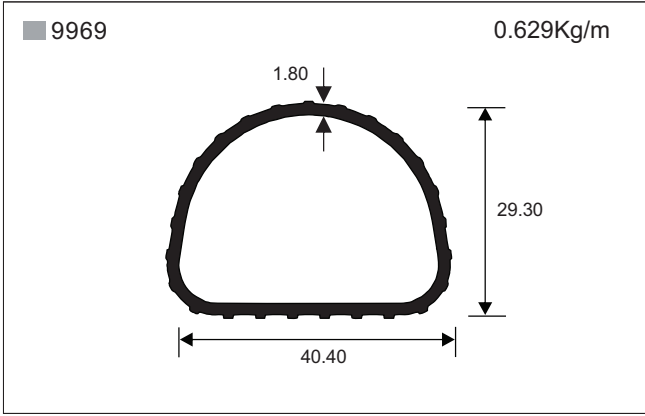



# MISCELLANEOUS

■ 2060 0.797Kg/m

93.00  
50.00  
1.50

Calendar stand

■ 8668 1.622Kg/m

1.80  
44.32  
91.80

Computer W/S

■ 3724 3.099Kg/m

175.00  
100.00  
3.00

Calendar stand

■ 3442 0.527Kg/m

2.80  
23.00  
23.00

Furniture

■ 2648 0.358Kg/m

29.00  
9.80  
2.00

Cooker Handle

■ 4411 1.071Kg/m

30.60  
29.00

Furniture

■ 85314 0.592Kg/m

19.05  
11.00

Pressure Cooker

■ 6641 0.649Kg/m

2.00  
44.50  
22.20

Furniture



# MISCELLANEOUS

■ 85403

0.519Kg/m

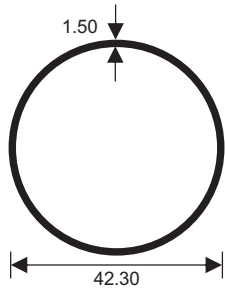

Harvest Pipe

■ 2099

0.419 Kg/m

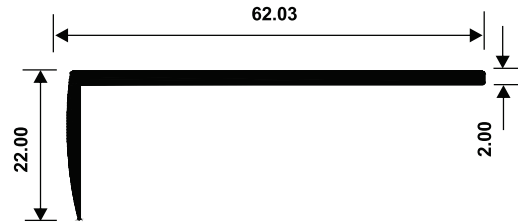

■ 90000

0.172Kg/m

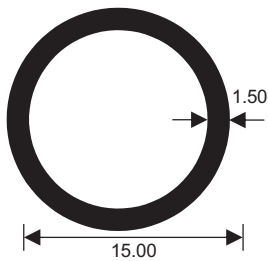

Harvest Pipe

■ 4412

0.465Kg/m

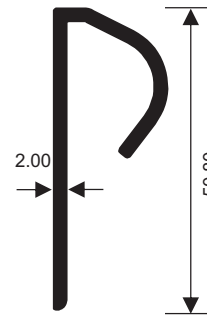

■ 85302

6.523Kg/m

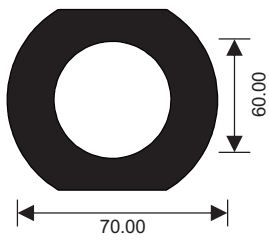

Header Water Filter

■ 5503

6.122Kg/m



■ 3713

0.364Kg/m

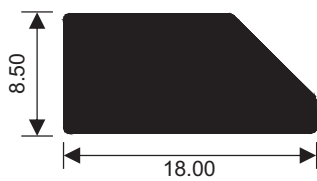

Horse Shoe

■ 7408

2.014Kg/m

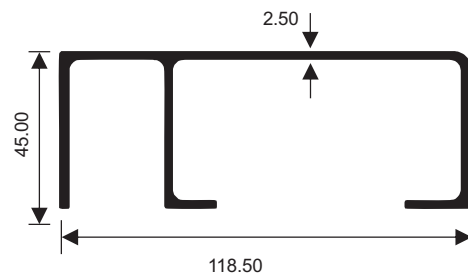

Alupuram



# MISCELLANEOUS

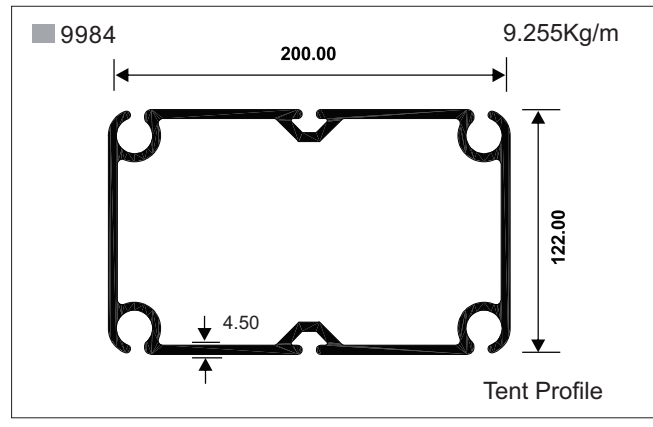
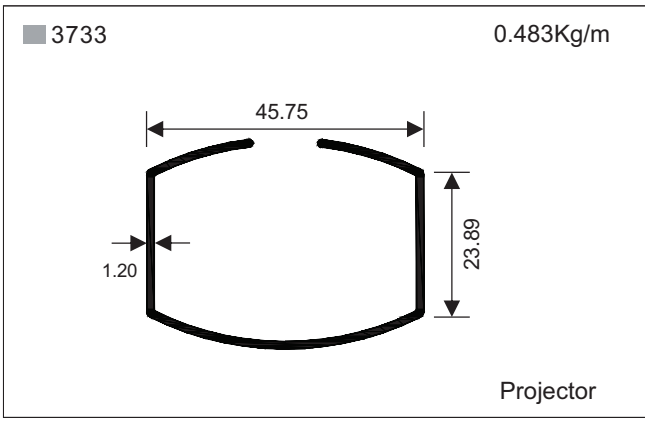
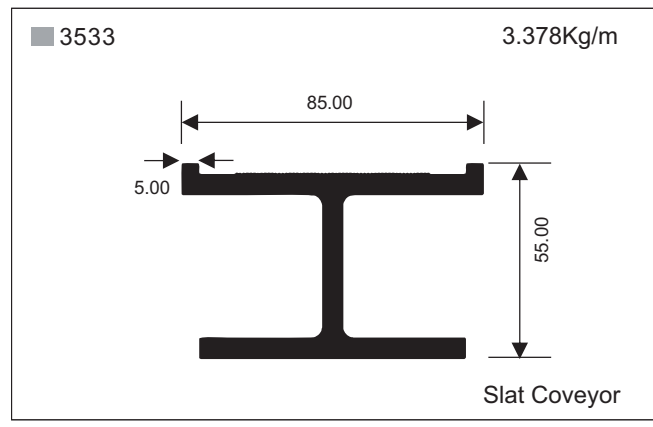
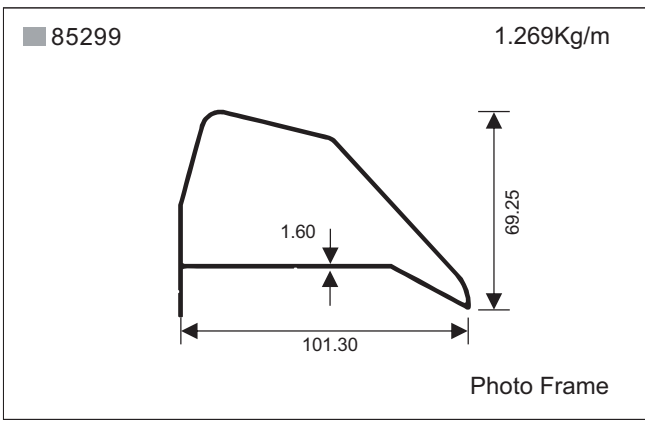
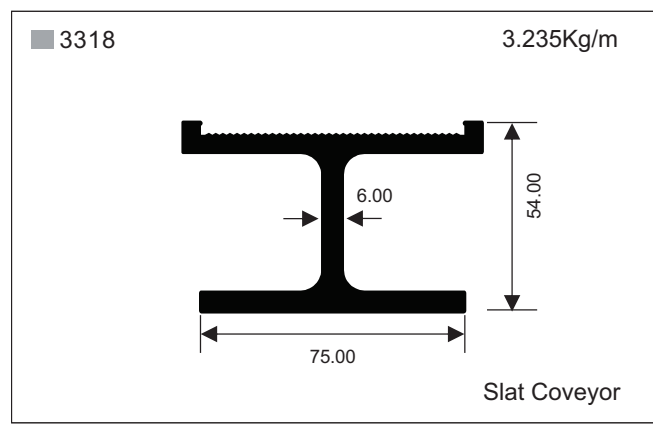
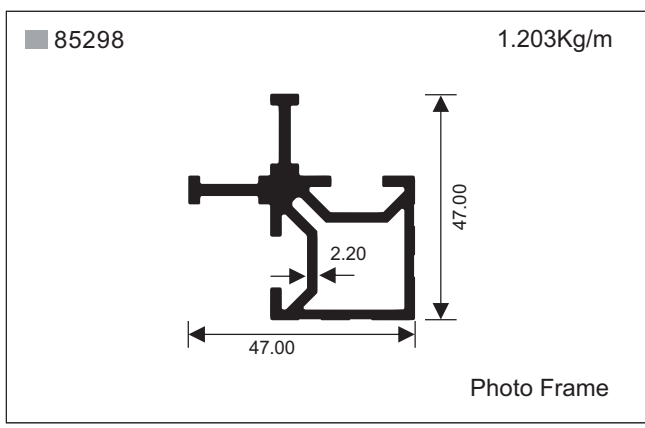
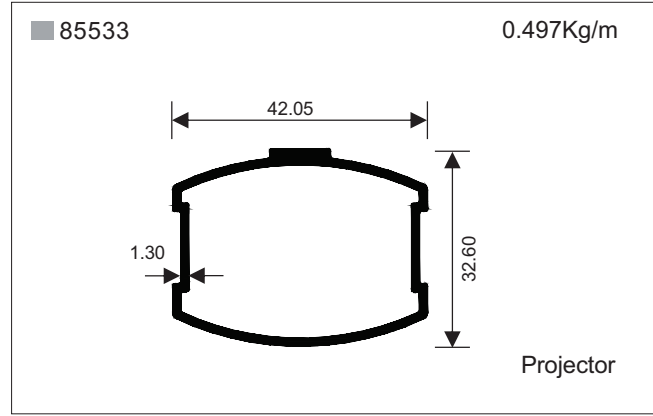
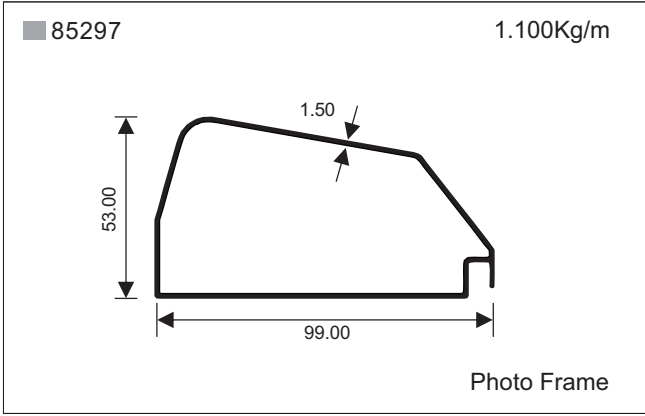

# Index



<u>SI No</u>	<u>Sec</u>	<u>Page</u>	<u>SI No</u>	<u>Sec</u>	<u>Page</u>	<u>SI No</u>	<u>Sec</u>	<u>Page</u>	<u>SI No</u>	<u>Sec</u>	<u>Page</u>
1	2060	21	50	7361	18						
2	2099	22	51	7379	18						
3	2648	21	52	7380	18						
4	2771	15	53	7382	18						
5	2785	15	54	7384	18						
6	3318	23	55	7388	19						
7	3442	21	56	7399	18						
8	3533	23	57	7408	22						
9	3713	22	58	7432	19						
10	3724	21	59	7508	19						
11	3733	23	60	7625	19						
12	4241	14	61	7629	18						
13	4242	14	62	7640	19						
14	4411	21	63	7837	19						
15	4412	22	64	7838	20						
16	4421	15	65	7839	19						
17	4422	15	66	7840	17						
18	4697	13	67	7841	17						
19	4698	13	68	7843	17						
20	4699	13	69	7844	17						
21	4700	14	70	8576	20						
22	5503	22	71	8614	17						
23	5613	13	72	8668	21						
24	5618	13	73	9313	20						
25	6002	13	74	9401	20						
26	6004	14	75	9434	20						
27	6010	14	76	9813	17						
28	6011	13	77	9822	20						
29	6430	13	78	9842	17						
30	6439	13	79	9844	20						
31	6502	18	80	9855	20						
32	6509	15	81	9969	20						
33	6541	15	82	9970	17						
34	6542	15	83	9984	23						
35	6543	16	84	85291	14						
36	6544	16	85	85292	14						
37	6589	18	86	85297	23						
38	6638	16	87	85298	23						
39	6641	21	88	85299	23						
40	6703	16	89	85302	22						
41	6739	16	90	85314	21						
42	6741	16	91	85403	22						
43	6742	16	92	85533	23						
44	6746	16	93	90000	22						
45	6842	15									
46	6861	19									
47	7046	18									
48	7356	18									
49	7357	18									





### MARKETING HEAD OFFICE

7th floor Birla Centurion,  
Pandurang Budhkar Marg, Worli  
Mumbai - 400 030  
Tel : +91 22 6662 6666, 6261 0555  
Fax: +91 22 2422 7586, 2436 2516  
Email : rajendra.pareek@adityabirla.com

### EXPORTS OFFICE

7th floor Birla Centurion,  
Pandurang Budhkar Marg, Worli  
Mumbai - 400 030  
Tel : +91 22 6662 6666, 6261 0555  
Fax: +91 22 2422 7586, 2436 2516  
Email : manoj.randive@adityabirla.com

### WORKS

P.O. Renukoot, Dist. Sonbhadra,  
Uttar Pradesh - 231 217, India  
Tel: +91-5446-252 079 / 78  
Fax: +91-5446-252 107 / 252 427  
Email: sanjeev.singh@adityabirla.com

P.B. No. 21 Alupuram, Kalamassery,  
Kerala - 683 104, India  
Tel: +91-484-293 2446  
Fax: +91-484-254 1887  
Email: r.sivaramakrishan@adityabirla.com

### REGIONAL OFFICES

#### North

Mindmill Corporate Tower  
24a, Film City  
Sec-16 A,  
Noida- 201301.up.  
Ph. + 91120 6692100  
Fax.91120 6692105  
Email: nutan.singh@adityabirla.com

#### East

Jeevan Deep Building, 1,  
Prafulla Chandra Sen Sarani,  
Kolkata - 700 071, West Bengal  
Tel: +91-33-2280 9710, 2288 6135  
Fax: +91-33-2288 6139  
Email: abhijit.chakraborty@adityabirla.com

#### West

1st floor, Ahura centre,  
82, Mahakali caves road, Andheri (East),  
Mumbai - 400 093, Maharashtra  
Tel: +91-22-6691 7000 / 7031  
Fax: +91-22-6691 7070/7050  
Email: ashish.nema@adityabirla.com

#### South

7th floor, Industry house,  
45 Race Course road,  
Bengaluru - 560 001, Karnataka  
Tel: +91-80-4041 6000  
Fax: +91-80-4041 6060  
Email: ashok.k.kumar@adityabirla.com

### AREA OFFICES

#### Kochi

P.B. No. 21 Alupuram, Kalamassery,  
Kerala - 683 104, India  
Tel: +91 484 254 2890, Fax: +91-484-254 1887  
Email: vivek.jacob@adityabirla.com

#### Chennai

Flat 2A, 2nd Floor, Appex Plaza, 3,  
Nungambakkam High Road, Chennai 600 034  
Tel: 91-44-2827 2333 / 2343  
Fax: 91-44-2827 4756  
Email: s.sugunaraj@adityabirla.com



[www.hindalco.com](http://www.hindalco.com)